

Service Manual

Finisher, Sorter, DeliveryTray Puncher Unit-N1

Canon

Application

This manual has been issued by Canon Inc. for qualified persons to learn technical theory, installation, maintenance, and repair of products. This manual covers all localities where the products are sold. For this reason, there may be information in this manual that does not apply to your locality.

Corrections

This manual may contain technical inaccuracies or typographical errors due to improvements or changes in products. When changes occur in applicable products or in the contents of this manual, Canon will release technical information as the need arises. In the event of major changes in the contents of this manual over a long or short period, Canon will issue a new edition of this manual.

The following paragraph does not apply to any countries where such provisions are inconsistent with local law.

Trademarks

The product names and company names used in this manual are the registered trademarks of the individual companies.

Copyright

This manual is copyrighted with all rights reserved. Under the copyright laws, this manual may not be copied, reproduced or translated into another language, in whole or in part, without the written consent of Canon Inc.

COPYRIGHT © 2001 CANON INC.









Printed in Japan

Caution

Use of this manual should be strictly supervised to avoid disclosure of confidential information.



Symbols Used

This documentation uses the following symbols to indicate special information:

Symbol	Description
	Indicates an item of a non-specific nature, possibly classified as Note, Caution, or Warning.
	Indicates an item requiring care to avoid electric shocks.
	Indicates an item requiring care to avoid combustion (fire).
	Indicates an item prohibiting disassembly to avoid electric shocks or problems.
	Indicates an item requiring disconnection of the power plug from the electric outlet.
 Memo	Indicates an item intended to provide notes assisting the understanding of the topic in question.
 REF.	Indicates an item of reference assisting the understanding of the topic in question.
	Provides a description of a service mode.
	Provides a description of the nature of an error indication.

The following rules apply throughout this Service Manual:

1. Each chapter contains sections explaining the purpose of specific functions and the relationship between electrical and mechanical systems with reference to the timing of operation.

In the diagrams,  represents the path of mechanical drive; where a signal name accompanies the symbol, the arrow  indicates the direction of the electric signal.

The expression "turn on the power" means flipping on the power switch, closing the front door, and closing the delivery unit door, which results in supplying the machine with power.

2. In the digital circuits, '1' is used to indicate that the voltage level of a given signal is "High", while '0' is used to indicate "Low". (The voltage value, however, differs from circuit to circuit.) In addition, the asterisk (*) as in "DRMD*" indicates that the DRMD signal goes on when '0'.

In practically all cases, the internal mechanisms of a microprocessor cannot be checked in the field. Therefore, the operations of the microprocessors used in the machines are not discussed: they are explained in terms of from sensors to the input of the DC controller PCB and from the output of the DC controller PCB to the loads.

The descriptions in this Service Manual are subject to change without notice for product improvement or other purposes, and major changes will be communicated in the form of Service Information bulletins.

All service persons are expected to have a good understanding of the contents of this Service Manual and all relevant Service Information bulletins and be able to identify and isolate faults in the machine."

Contents

Chapter 1 Specifications

1.1 Product Specifications	1- 1
1.1.1 Specifications	1- 1
1.2 Names of Parts.....	1- 3
1.2.1 External View	1- 3
1.2.2 Cross Section	1- 4

Chapter 2 Functions

2.1 Basic Construction	2- 1
2.1.1 Functional Construction	2- 1
2.2 Feed Drive System	2- 2
2.2.1 Overview	2- 2
2.2.2 Construction of the Control System	2- 2
2.2.3 Punch Operation	2- 4
2.2.4 Horizontal Registration Operation	2- 7
2.3 Detecting Jams	2- 10
2.3.1 Detecting Jams	2- 10
2.4 Power Supply	2- 11
2.4.1 Power Supply Route	2- 11
2.4.2 Protection Function	2- 11

Chapter 3 Installation

3.1 Making Pre-Checks	3- 1
3.1.1 Checking the Contents.....	3- 1
3.1.2 Installing the Accessories	3- 3
3.2 Unpacking and Chacking the Components	3- 4
3.2.1 Unpacking	3- 4
3.3 Installation Procedure.....	3- 5
3.3.1 Disconnecting the Finisher from its Host Machine.....	3- 5
3.3.2 Connecting to the Finisher	3- 8
3.3.3 Preparing the Host Machine for Installation	3- 10
3.3.4 Connecting to the Host Machine	3- 11
3.3.5 Checking the Height/Tilt	3- 13
3.4 Making Adjustments	3- 15
3.4.1 Adjusting the Height/Tilt.....	3- 15
3.4.2 Work After Making Checks/Adjustments	3- 17
3.5 Ataching the Labels etc	3- 21
3.5.1 Attaching the Label	3- 21

Chapter 4 Parts Replacement Procedure

4.1 External Covers	4- 1
4.1.1 Rear Cover	4- 1
4.1.2 Upper Cover	4- 1
4.1.3 Right Guide Unit	4- 1
4.2 Drive System	4- 2
4.2.1 Punch Motor	4- 2
4.2.2 Horizontal Registration Motor	4- 2
4.2.3 Punch Unit	4- 3
4.3 Electrical System	4- 7
4.3.1 Punch Unit Harness	4- 7
4.3.2 LED PCB	4- 9
4.3.3 Photosensor PCB	4- 12
4.3.4 Scrap Full Detector PCB	4- 13
4.3.5 Punch Controller PCB	4- 14

Chapter 5 Maintenance

5.1 User Maintenance	5- 1
5.1.1 User Maintenance	5- 1
5.2 Maintenance and Inspection	5- 2
5.2.1 Periodically Replaced Parts	5- 2
5.2.2 Durables	5- 2
5.2.3 Periodical Servicing	5- 2
5.3 Adjustment	5- 3
5.3.1 Adjustment at Time of Parts Replacement	5- 3
5.4 Troubleshooting	5- 5
5.4.1 Error Code	5- 5
5.5 Outline of Electrical Components	5- 7
5.5.1 Sensors	5- 7
5.5.2 Microswitches	5- 8
5.5.3 Motors	5- 9
5.5.4 PCBs	5- 10
5.6 Variable Resistors (VR), Light-Emitting Diodes (LED), and Check Pins by PCB	5- 12
5.6.1 Overview	5- 12
5.6.2 Punch Controller PCB	5- 12
5.7 Upgrading	5- 13
5.7.1 Upgrading	5- 13
5.8 Service Tools	5- 21
5.8.1 Solvents and Oils	5- 21

Chapter 6 Error Code

6.1 Overview	6- 1
6.1.1 Overview	6- 1
6.2 User Error Code	6- 2
6.2.1 Punch scrap full	6- 2
6.2.2 Punch scrap overflow	6- 2
6.3 Service Error Code	6- 3
6.3.1 E503	6- 3

6.3.2E505.....	6- 3
6.3.3E590.....	6- 3
6.3.4E591.....	6- 4
6.3.5E592.....	6- 5
6.3.6E593.....	6- 8

Chapter 1 Specifications

Contents

1.1 Product Specifications	1-1
1.1.1 Specifications	1-1
1.2 Names of Parts.....	1-3
1.2.1 External View.....	1-3
1.2.2 Cross Section.....	1-4

1.1 Product Specifications

1.1.1 Specifications

0003-4694

T-1-1

Item	Specifications	Remarks
Punching method	Reciprocating punching (Sequential punch-ing)	
Paper size	2 holes (Puncher Unit-L1): A3, A4, A4R, B4, B5, B5R 2 or 3 holes (Puncher Unit-M1): 2 holes/LGL, LTRR 3 holes/279mm x 432mm (11 x 17), LTR 4 holes (FRA)(Puncher Unit-N1): A3, A4 4 holes (SWD)(Puncher Unit-P1): A3, A4	
Paper weight	64g/m2 to 250g/m2	Transparenie s not allowed
Punched hole diameter	2 holes : 6.5mm 2 or 3 holes : 8mm 4 holes : 6.5mm	
Punched scrap capacity	2 holes: 10,000 sheets or more 2 or 3 holes: 3,000 sheets or more 4 holes: 5,000 sheets or more	80 g/m2 or equivalent
Dimensions	107 x 615 x 378mm (W x D x H)	
Weight	Approx. 7.2 kg	
Power supply	From finisher unit (24 VDC / 5 VDC)	

Hole position

[1] Puncher unit-L1 (2-Hole)

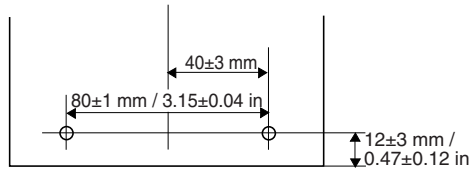

[2] Puncher unit-M1 (2-/3-Hole)

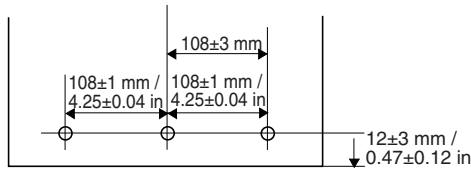
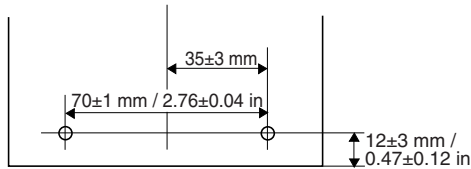

[3] Puncher unit-N1 (4-Hole (FRA))

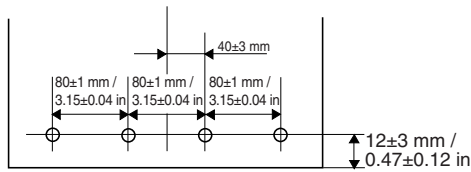

[4] Puncher unit-P1 (4-Hole (SWD))

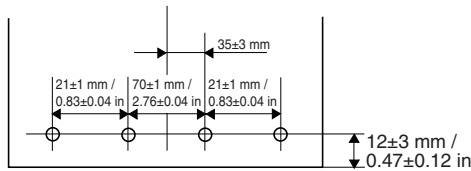

F-1-1

1.2 Names of Parts

1.2.1 External View

0003-4695

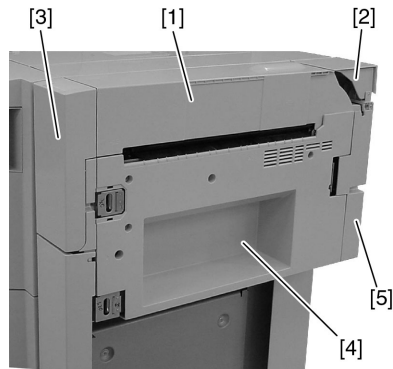

F-1-2

T-1-2

[1] Upper cover

[2] Upper cover 2

[3] Front door

[4] Right guide assembly

[5] Rear cover

1.2.2 Cross Section

0003-4696

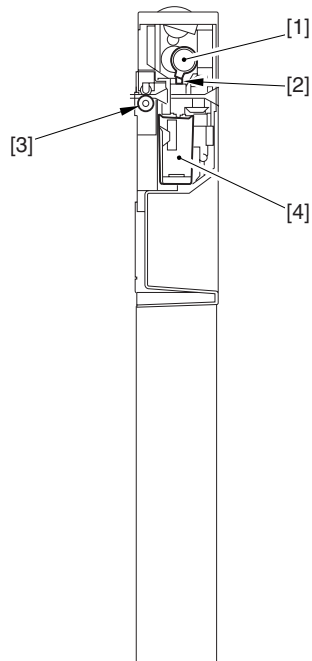

F-1-3

T-1-3

[1] Cam

[3] Punch feed roller

[2] Hole puncher (Punch blade)

[4] Punch waste case

Chapter 2 Functions

Contents

2.1 Basic Construction	2-1
2.1.1 Functional Construction	2-1
2.2 Feed Drive System	2-2
2.2.1 Overview	2-2
2.2.2 Construction of the Control System	2-2
2.2.3 Punch Operation	2-4
2.2.4 Horizontal Registration Operation	2-7
2.3 Detecting Jams	2-10
2.3.1 Detecting Jams	2-10
2.4 Power Supply	2-11
2.4.1 Power Supply Route	2-11
2.4.2 Protection Function	2-11

2.1 Basic Construction

2.1.1 Functional Construction

0003-8735

The puncher unit is optionally installed in the delivery path between the host machine and the finisher. When the paper delivered from the host machine reaches the puncher unit, it is fed by the punch feed roller. Then when the trailing edge of the paper is detected, the paper is temporarily stopped and the punch axis rotates to punch holes in the trailing edge of the paper. These operations are controlled by the finisher controller PCB and the punch controller PCB drives each puncher component.

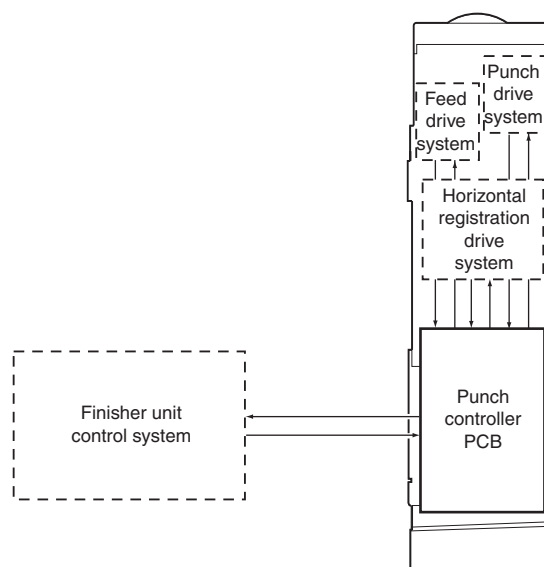

F-2-1

2.2 Feed Drive System

2.2.1 Overview

0003-9479

The puncher unit is located on the feed path between the host machine and the finisher, and successively punches holes when the paper stops temporarily.

The paper delivered from the host machine is fed by the punch feed roller. The punch feed roller is driven by the punch feed motor. When the trailing edge of the paper reaches the puncher unit, the inlet roller of the finisher unit temporarily stops the paper and holes are punched on the trailing edge of the paper.

The following shows the names and functions of the motors and sensors used in punching operation:

T-2-1

Motor	Function
Punch motor (M61)	Drives the punch unit.
Horizontal registration motor (M62)	Drives the punch slide unit.
Punch feed motor(M63)	Drives the punch feed roller.

T-2-2

Sensor	Function
Horizontal registration home position sensor (PI61)	Detects the punch slide unit home position.
Punch motor clock sensor (PI62)	Detects the punch motor clock.
Punch home position sensor (PI63)	Detects the punch shaft home position.
Horizontal registration sensor (LED1 to LED4,PTR1 to PTR4)	Detects the position of the rear edge of paper.
Trailing edge sensor (LED5,PTR5)	Detects the trailing edge of paper.
Scrap full detector sensor (LED6,PTR6)	Detects the state of the punch waste case (full).

2.2.2 Construction of the Control System

0003-4698

The puncher unit consists of a die and hole puncher (punch blade).

The hole puncher is driven by the punch motor (M61). The hole puncher is attached to the eccentric cam of the punch shaft, and rotary action of the punch shaft is converted to reciprocal motion to perform punching.

Punch motor (M61) is a DC motor. The home position of the punch shaft is detected by punch home position sensor

(PI63). To stop the DC punch motor accurately at its home position, the punch motor clock sensor (PI62) counts a predetermined number of clock pulses to stop the punch motor. A single punch operation is performed by rotating the punch shaft 180° from its home position.

Five light sensors (photosensor PCB) are located at the upper side of the inlet paper feed path of the puncher unit and a set of five LEDs (LED PCB) are located at the lower side. These sensors and LEDs function as five sensors. The frontmost sensor (LED5, PTR5) are the trailing edge sensor and are used for detecting the trailing edge of the paper. The remaining sensors (LED1 to LED4, PTR1 to PTR4) are horizontal registration sensors, and are used for detecting the inner position of the paper for determining the hole punching position.

The punch motor, puncher unit and above sensors comprise the punch slide unit. This unit moves backwards and forwards according to the size of the paper. Backward and forward movement is driven by the horizontal registration motor (M62). The home position of the punch slide unit is detected by the horizontal registration home position sensor (PI61). The horizontal registration motor (M62) is a 2-phase stepping motor.

The punch motor and horizontal registration motor is driven by the punch controller PCB according to control signals from the finisher controller PCB.

Punch scraps caused by punching are stored in the punched scrap container. Scrap full detection is performed by a reflective sensor (LED6 and PTR6 on the scrap full detector PCB unit).

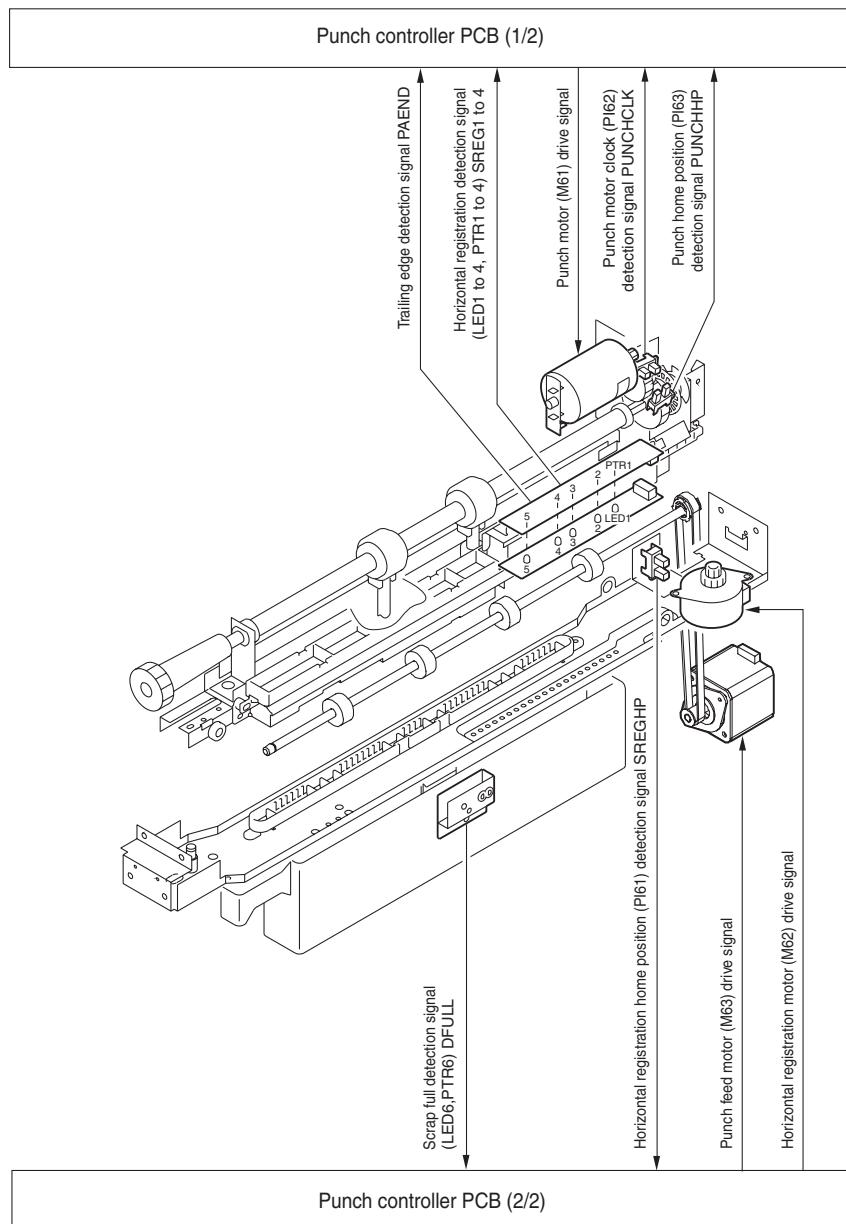

F-2-2

2.2.3 Punch Operation

0003-4699

The hole puncher is driven by the punch motor (M61), and its position is monitored by the punch home position sensor (PI63).

The hole puncher makes a single round-trip movement (punching) as the punch shaft rotates 180° from home position.

In the case of a 2-or-3 hole type, the half sector of the punch shaft is used when punching 2 holes while the half sector on the opposite side is used when punching 3 holes as instructed by the host machine.

<2-/4-hole Type>

At the home position, the punch home position sensor is ON. Punching of the first sheet ends when the punch shaft has rotated in the forward direction 180° , and the state of the punch home position sensor has changed from OFF to ON. Punching of the second sheet ends when the punch shaft has rotated in the reverse direction 180° , and the state of the punch home position sensor has changed from OFF to ON.

The following illustrates punching when two sheets are punched.

1) A hole is punched in the trailing edge of the first sheet.

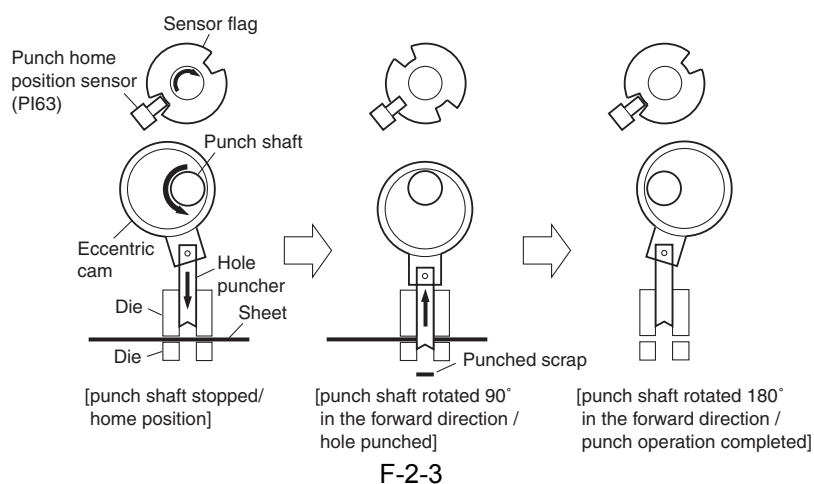

2) A hole is punched in the trailing edge of the second sheet.

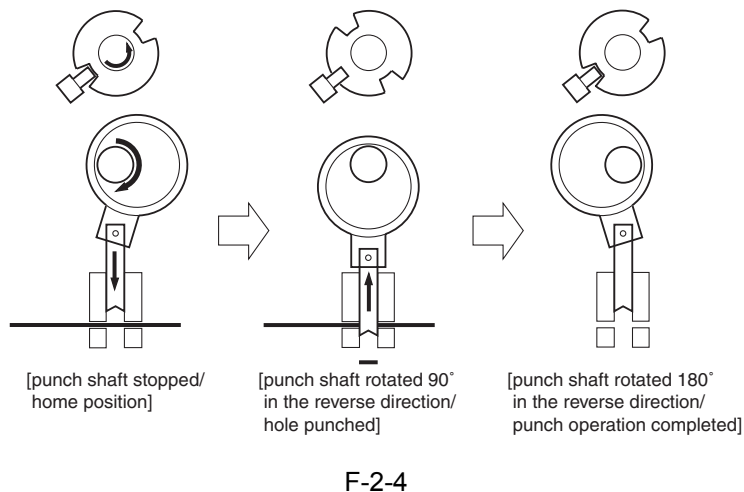

<2-/3-hole Dual Use Type>

At the home position, the punch home position sensor is ON. To punch two holes, punching of the first sheet ends when the punch shaft half peripheral area has rotated in the forward direction 180° , and the state of the punch home position sensor has changed from OFF to ON. At this time, the 3-hole puncher is moved reciprocally in the escape direction (hole puncher rise direction) on the remaining half peripheral area on the punch shaft. Punching of the second sheet ends when the punch shaft half peripheral area has rotated in the reverse direction 180° , and the state of the punch home position sensor has changed from OFF to ON. Also at this time, the 3-hole puncher is moved

reciprocally in the escape direction (hole puncher rise direction) on the remaining half peripheral area on the punch shaft. To punch three holes, the 2-hole puncher is moved reciprocally in the escape direction (hole puncher rise direction).

The following illustrates punching when two sheets are punched with two holes.

1) A hole is punched in the trailing edge of the first sheet.

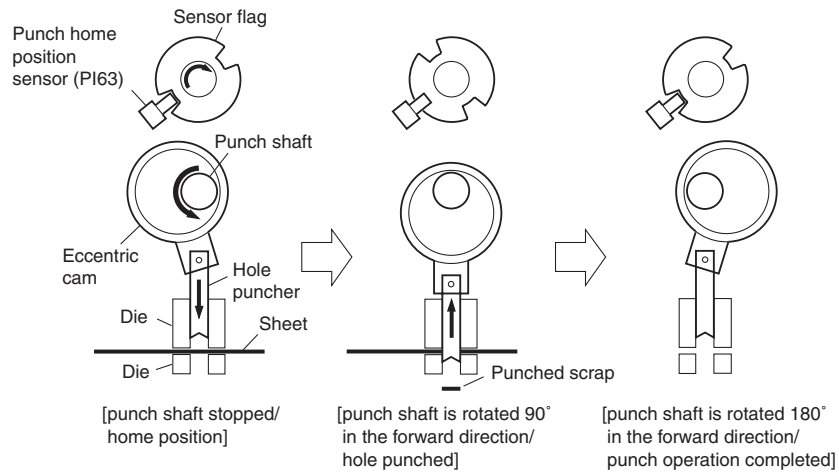

F-2-5

When two holes are punched, the 3-hole puncher is fed reciprocally in the escape direction (hole puncher rise direction) as shown below.

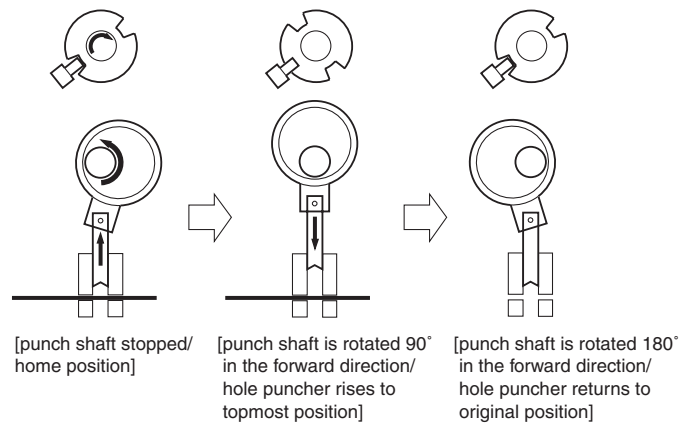

F-2-6

2) A hole is punched in the trailing edge of the second sheet.

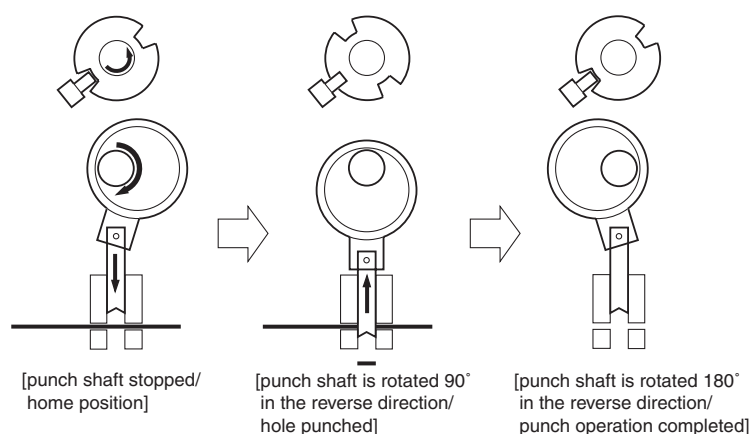

F-2-7

When two holes are punched, the 3-hole puncher is fed reciprocally in the escape direction (hole puncher rise direction) as shown below.

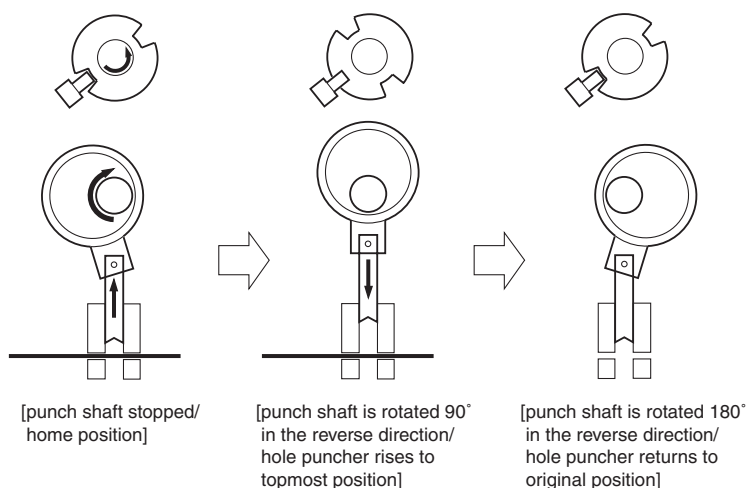

F-2-8

2.2.4 Horizontal Registration Operation

0003-4700

Horizontal registration drive of the punch slide unit is performed by the horizontal registration motor (M62). The home position of the punch slide unit is detected by the horizontal registration home position sensor (PI61). The punch slide unit detects the trailing edge of the paper by the trailing edge sensor (LED5, PTR5) and horizontal registration sensors (LED1 to 4, SREG1 to 4) and is moved to the trailing edge position matched to the paper size. The following shows horizontal registration operation.

- 1) When the leading edge of the paper from the host machine is detected by the trailing edge sensor (LED5, PTR5) on the puncher unit, the horizontal registration motor (M62) starts to move the punch slide unit towards the front.

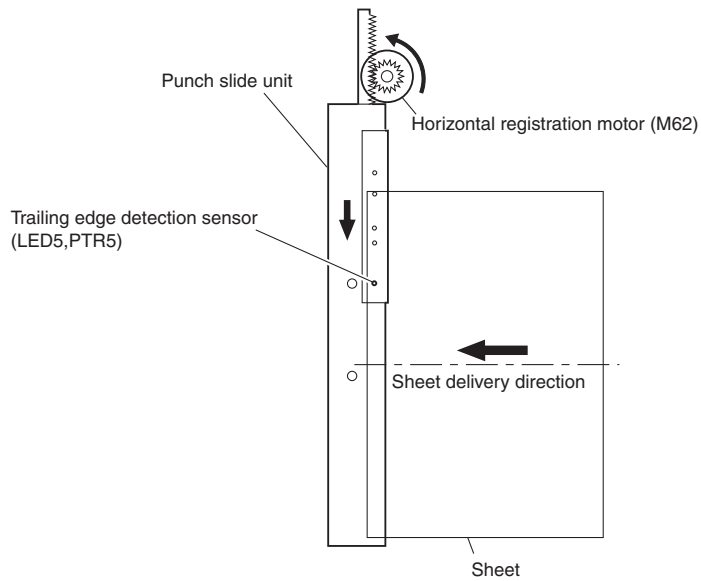

F-2-9

2) After the horizontal registration sensors (LED1 to 4, PTR1 to 4) detect the edge of the paper at its inner side in keeping with the paper size signals arriving from the host machine, the horizontal registration motor (M62) drives the punch slide unit to a predetermined position further towards the front, and stops the unit at this position.

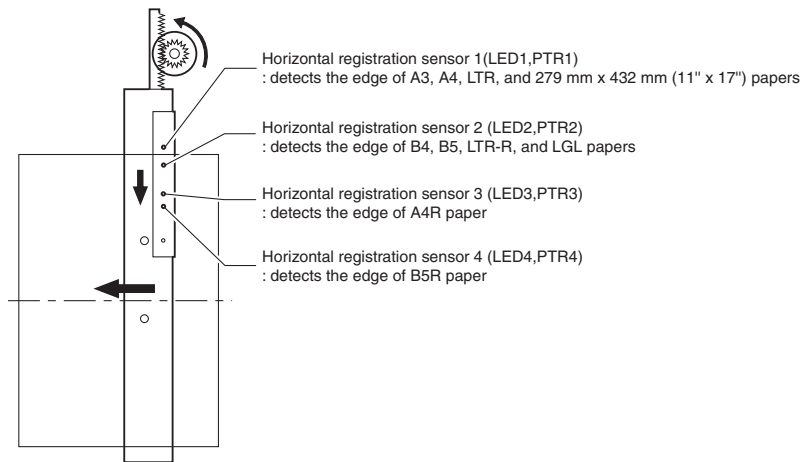

F-2-10

3) When the trailing edge sensor (LED5, PTR5) detects the trailing edge of the paper, drive of the punch feed motor (M63) is stopped to stop paper feed. Next, the punch motor (M161) is driven to punch holes in the paper.

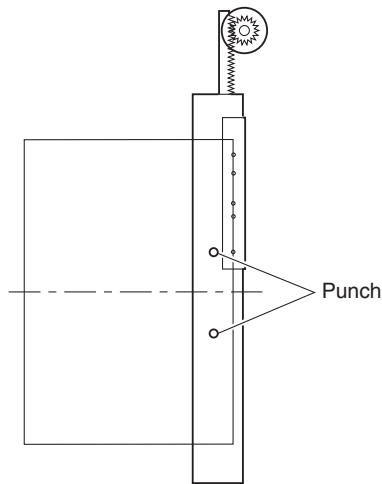

F-2-11

- 4) When punching ends, drive of the punch feed motor (M63) is started, the horizontal registration motor (M62) is operated in the reverse direction, and the punch slide unit is returned to its home position where it comes to a stop.
- 5) Even if paper to be punched continues to arrive, the punch slide unit returns to its home position for each arriving sheet, and steps 1 to 4 are repeated.

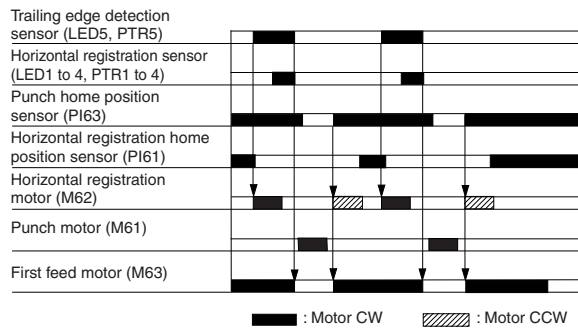

F-2-12

2.3 Detecting Jams

2.3.1 Detecting Jams

0003-4704

The finisher unit identifies any of the following conditions as a jam, and sends the jam signal to the host machine. In response, the host machine may stop copying operation and indicate the presence of a jam on its control panel.

T-2-3

Jam type	Sensor	Jam Condition	Code
Feeding delay	LED,PTR5	When the rear end sensor (LED, PTR5) does not detect paper after a prescribed time (distance) has elapsed since receiving a delivery signal from the host machine.	1002
Feeding stationary	LED,PTR5	When paper does not exit the rear end sensor (LED, PTR5) after feeding for a prescribed time (distance) after the rear end sensor (LED, PTR5) has detected paper.	1102
Punch	PI63	When the punch home position sensor (PI63) does not turn on after a prescribe time has elapsed since it is turned off.	1644
Power-on	LED,PTR5	When paper is detected by the rear end sensor (LED, PTR5) during power on.	1645

2.4 Power Supply

2.4.1 Power Supply Route

0003-4702

24V power and 5V power are supplied from the finisher controller PCB when the power switch on the host machine is turned ON.

24V power is used for driving motors, while 5V power is used for driving sensors and the ICs on the punch controller PCB.

24V power to the motors is not supplied when either of the two door switches on the puncher unit is open.

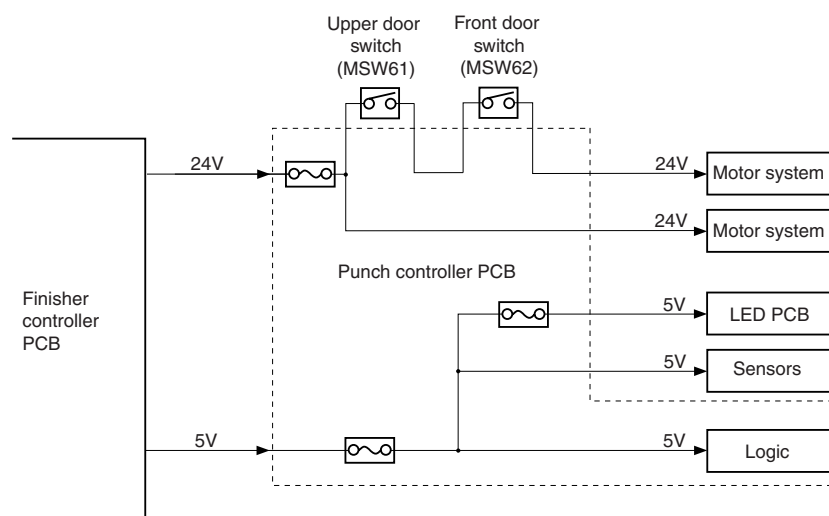

F-2-13

2.4.2 Protection Function

0003-4703

The 24V power supplies are equipped with a fuse designed to blow when an overcurrent flows.

Chapter 3 Installation

Contents

3.1 Making Pre-Checks	3-1
3.1.1 Checking the Contents.....	3-1
3.1.2 Installing the Accessories	3-3
3.2 Unpacking and Chacking the Components	3-4
3.2.1 Unpacking	3-4
3.3 Installation Procedure.....	3-5
3.3.1 Disconnecting the Finisher from its Host Machine.....	3-5
3.3.2 Connecting to the Finisher	3-8
3.3.3 Preparing the Host Machine for Installation	3-10
3.3.4 Connecting to the Host Machine	3-11
3.3.5 Checking the Height/Tilt	3-13
3.4 Making Adjustments	3-15
3.4.1 Adjusting the Height/Tilt.....	3-15
3.4.2 Work After Making Checks/Adjustments.....	3-17
3.5 Ataching the Labels etc.	3-21
3.5.1 Attaching the Label	3-21

3.1 Making Pre-Checks

3.1.1 Checking the Contents

0003-0202

<Finisher-Q1/Saddle Finisher-Q2>

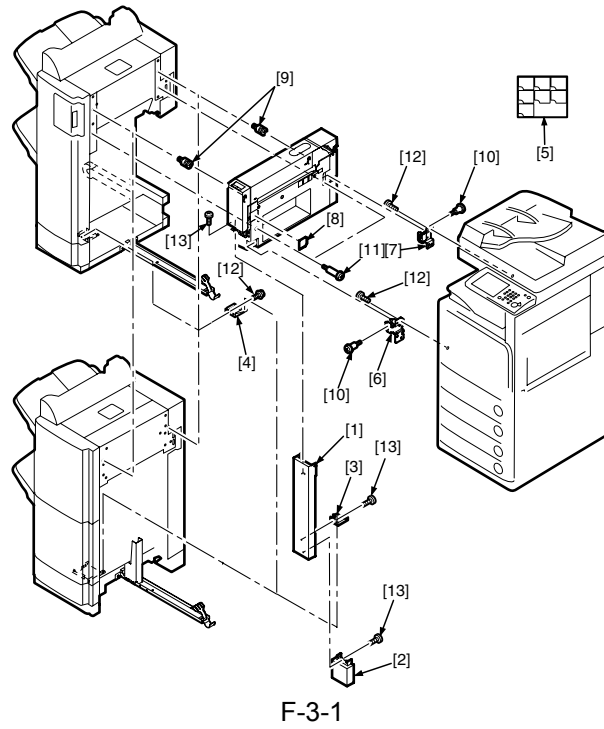

<Finisher-R1/Saddle Finisher-R2>

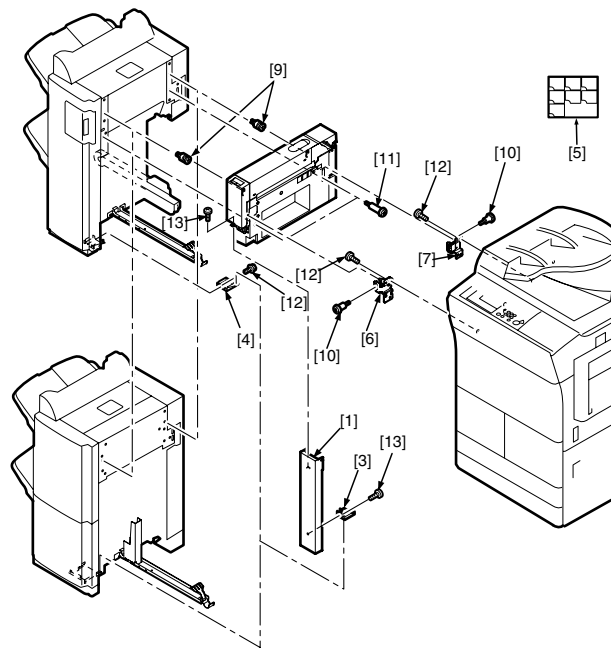

F-3-2

T-3-1

[1]Punch front lower cover	1 pc.	[8]Surface cover	1 pc.*1
[2]Punch front lower extension cover	1 pc.*1	[9]Mounting stepped screw	2 pc.
[3]Punch front lower cover fixing plate 1	1 pc.	[10]Stepped screw (M4)	2 pc.
[4]Punch front lower cover fixing plate 2	1 pc.*2	[11]Stepped screw (M4x10)	2 pc.
[5]Punch Jam Removal label	1 pc.	[12]Screw (binding; M4x6)	5 pc.*3
[6]Punch fixing plate (FC5-4098)	1 pc.	[13]Screw (tapping; M4x2)	3 pc.*4
[7]Punch fixing plate (FC5-4076)	1 pc.		

*1: Only for the Finisher-Q1/Saddle Finisher-Q2.

*2: Only for the Finisher-Q1/R1.

*3: 4 pc. used if for the Saddle Finisher-Q2/R2.

*4: 2 pc. used if for the Finisher-R1/Saddle Finisher-R2.

3.1.2 Installing the Accessories

0003-0203

If you are installing the puncher unit at the same time as other accessories, be sure to install the host machine and then install the accessories in the following order:

- 1.Side paper deck (See the Side Paper Deck Installation Procedure.)
- 2.Finisher [1], [2] (See "Preparing for the Installation of the Finisher" in the Finisher/Saddle Finisher Installation Procedure.)
- 3.Relay delivery unit [3] and buffer pass unit [4] (See "Installing the Relay Delivery Unit and the Buffer Pass Unit" in the Finisher/Saddle Finisher Installation Procedure.)
- 4.Additional finisher tray [5] (See the Additional finisher tray Installation Procedure.)
- 5.Puncher unit [6] (See the instructions herein.)
- 6.Connection to the host machine (See "Connecting to the Host Machine" and thereafter.)

In the case of the Finisher-R1/R2, the relay delivery unit [3] and the buffer pass unit [4] are not part of the configuration. The figure shows the Finisher-Q1/Q2.

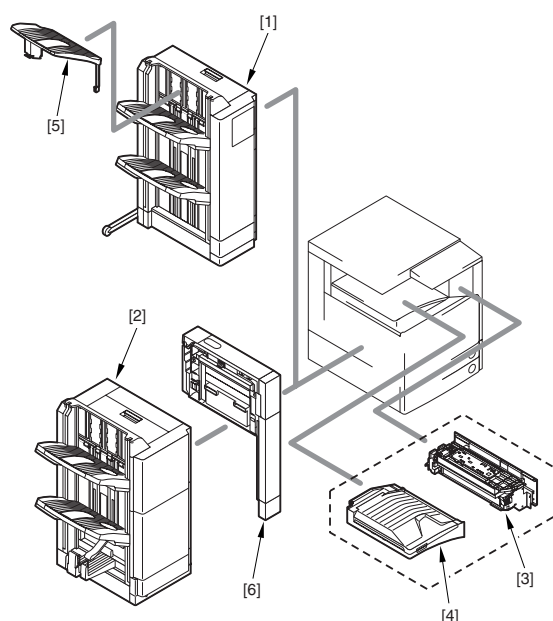

F-3-3

⚠ Before starting to install an accessory, be sure to go through the following steps in strict order:

1. Turn off the host machine's control panel power switch.
2. Turn off the host machine's main power switch.
3. Disconnect the host machine's power plug (from the power outlet).

3.2 Unpacking and Chacking the Components

3.2.1 Unpacking

0003-0205

Memo: The machine is fitted with tape and cushioning material to protect against vibration and shock during transit. Be sure to remove all of it as instructed before the installation work. It is a good idea to store away the removed tape and cushioning material for possible future relocation and shipment for repairs.

- 1) Remove the attachments and the puncher unit from the shipping box.
- 2) Remove the tape from the outside of the puncher unit.
- 3) Open the punch upper cover.
- 4) Remove the 2 fixing screws [1] each, and detach the front and rear punch fixing plates [2].

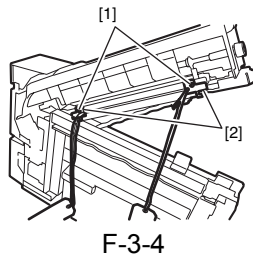

3.3 Installation Procedure

3.3.1 Disconnecting the Finisher from its Host Machine

0003-0206

⚠If a finisher has been installed, you will have to disconnect it from its host machine before installing the puncher unit. If you are installing the finisher and the puncher unit at the same time, on the other hand, install the finisher as instructed in "Preparing for the Installation of the Finisher" ; and then, go through the steps under "Connecting to the Finisher" herein.

1) Turn off the host machine, and disconnect the power plug (from the power outlet).

2) Disconnect the interface cable [1] of the finisher from the host machine.

<Finisher-Q1/Q2>

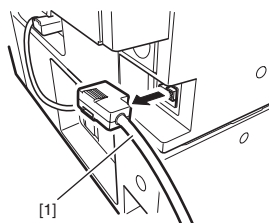

F-3-5

<Finisher-R1/R2>

Free the interface cable [1] from the cable clamp [2].

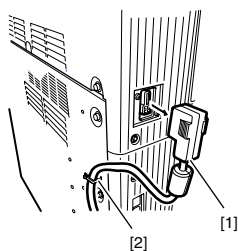

F-3-6

3) In the case of the Finisher-Q1/R1, remove the foot cover and the extension cover (if Finisher-Q1).

<Finisher-Q1>

Remove the screw [1], and detach the lower front extension cover [2]. Remove the screw [1], and detach the front foot cover [3].

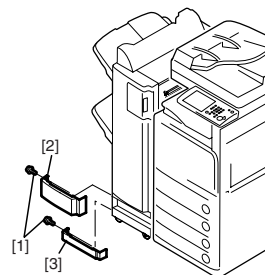

F-3-7

<Finisher-R1>

Remove the screw [1], and detach the front foot cover [2].

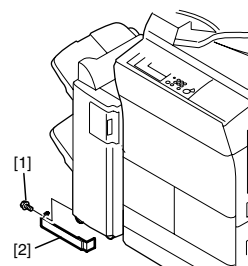

F-3-8

4) Remove the front cover.

<Finisher-Q1/R1>

Open the front door [1], and remove the 3 screws [2]; then, detach the front cover [3]. (The figure shows the Finisher-Q1.)

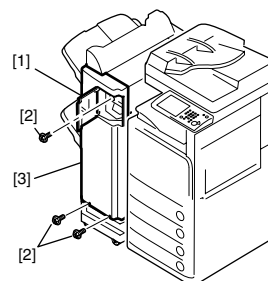

F-3-9

<Saddle Finisher-Q2/R2>

Open the front cover. (The figure shows the Finisher-Q2.)

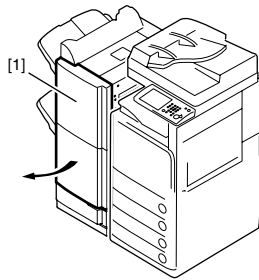

F-3-10

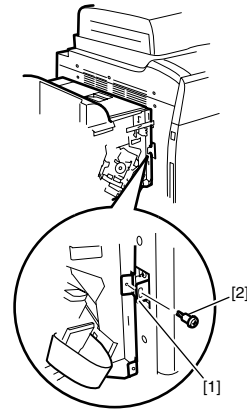

F-3-12

5) Disconnect the finisher at the front from its host machine.

<Finisher-Q1/Q2>

Remove the stepped screw [2], and detach the fixing plate [1] (front) of the host machine; then, disconnect the finisher (front) from its host machine. (The figure shows the Finisher-Q1.)

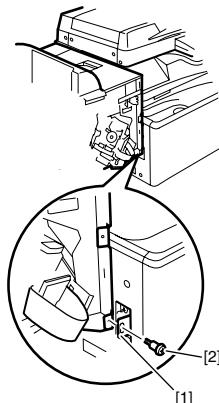

F-3-11

6) Remove the screw [1], and detach the upper rear (small) cover [2] of the finisher; then, remove the stepped screw [3], and disconnect the finisher at the rear from its host machine.

<Finisher-Q1/Q2>

(The figure shows the Finisher-Q1.)

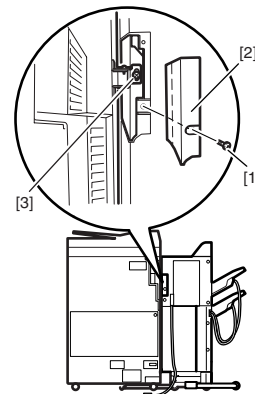

F-3-13

<Finisher-R1/R2>

Remove the stepped screw [2], and detach the fixing plate [1] (front) of the host machine; then, disconnect the finisher (front) from its host machine. (The figure shows the Finisher-R1.)

<Finisher-R1/R2>

(The figure shows the Finisher-R1.)

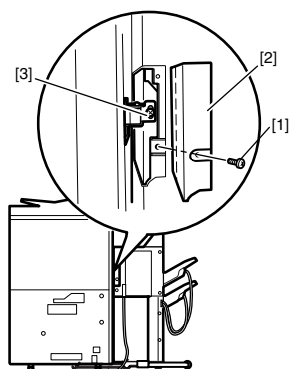

F-3-14

7) In the case of the Saddle Finisher-Q2/R2, close the front cover. In the case of the Finisher-Q1/R1, mount the front cover using 3 screws.

8) In the case of the Saddle Finisher-Q2/R2, remove the foot cover and the extension cover (if Saddle Finisher-Q2).

<Saddle Finisher-Q2>

Remove the 2 screws [1] and [2], and detach the lower front extension cover [3]. Remove the screw [1], and detach the front foot cover [4]. Remove the screw [1], and detach the rear foot cover [5].

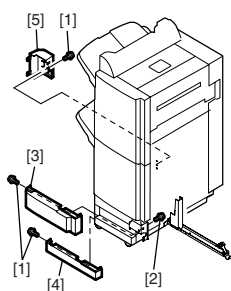

F-3-15

<Saddle Finisher-R2>

Remove the screw [1], and detach the front foot cover [2]. Remove the screw [1], and detach the rear foot cover [3].

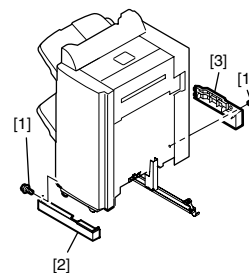

F-3-16

9) In the case of the Finisher-Q1, remove the 2 screws [1], and detach the inlet guide [2]; then, remove the 4 screws [3], and detach the right cover [4].

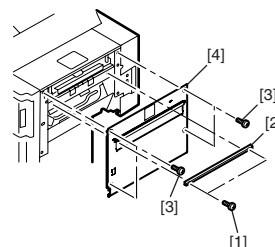

F-3-17

⚠ If the finisher is a Finisher-Q1/Q2 and, moreover, a rubber sheet that comes with the buffer pass unit is attached to the pickup surface of the finisher, leave the rubber sheet as it is. Be sure that the rubber sheet you may be attaching to the pickup surface of the puncher unit is a new one.

10) Remove the 2 screws [1], and detach the 2 fixing plates [2] and [3] of the host machine.

<Finisher-Q1/Q2>

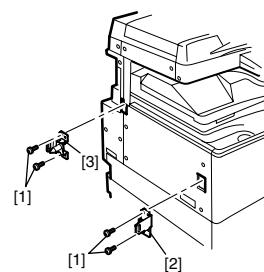

F-3-18

<Finisher-R1/R2>

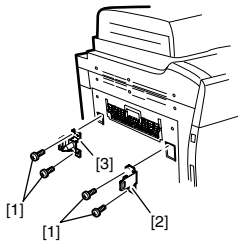

F-3-19

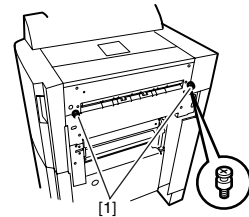

F-3-22

3.3.2 Connecting to the Finisher

0003-0207

1) In the case of the Finisher-Q1, remove the 2 screws [1], and detach the inlet guide [2]; then, remove the 4 screws [3], and detach the right cover [4]. (Skip this step if it has already been removed.)

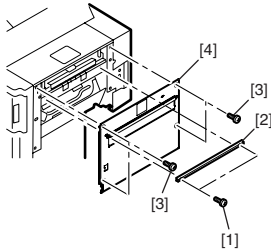

F-3-20

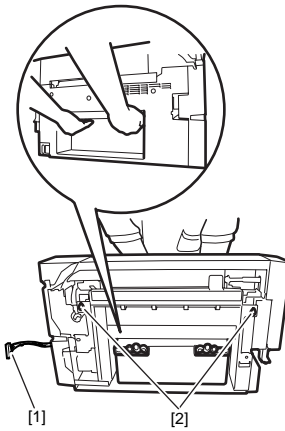

F-3-23

2) Fit the 2 mounting stepped screws [1] to the pickup assembly of the finisher.

<Finisher-Q1/R1>

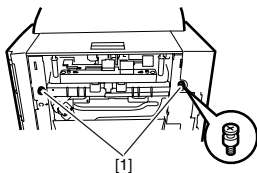

F-3-21

<Saddle Finisher-Q2/R2>

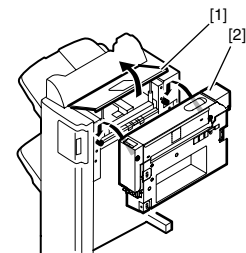

F-3-24

3) Route the connector cable [1] of the puncher unit to the rear; hold it as shown, and hook the hole [2] of the joint assembly on the 2 mounting stepped screws.

⚠In the case of the Finisher-Q1/R1, the joint assembly may interfere. Keep the upper cover [1] of the finisher open when hooking it on the puncher unit [2].

4) Secure the puncher unit to the finisher using 2 stepped screws [1] (M4x10).

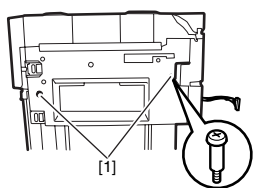

F-3-25

5) Remove the rear cover from the finisher.

<Finisher-Q1/R1>

Remove the 3 screws [1], and detach the rear cover [2].

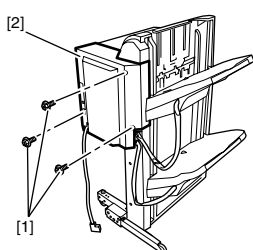

F-3-26

<Saddle Finisher-Q2/R2>

Detach the cable cover [1], and remove the 6 screws [2]; then, detach the rear cover [3].

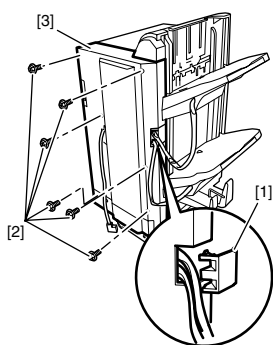

F-3-27

6) Remove the screw [1], and detach the upper rear (small) cover [2] of the finisher. (Skip this step if it has already been removed.)

7) Cut off the surface cover [3] using nippers.

<Finisher-Q1/R1>

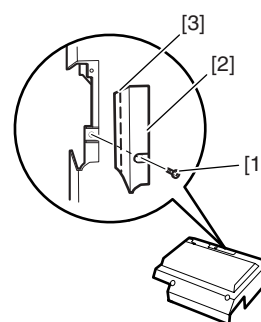

F-3-28

<Saddle Finisher-Q2/R2>

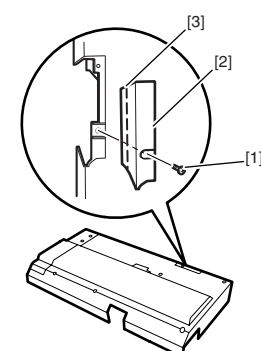

F-3-29

8) Connect the connector of the puncher unit to the connector of the finisher PCB securely.

▲ Check to make sure that the connector is fully in contact. If the puncher unit happens to malfunction after installation, try disconnecting and then connecting the connector to see the fault has been corrected.

<Finisher-Q1/R1>

Connect to the connectors J705 [1] and J706 [2] of the finisher controller PCB.

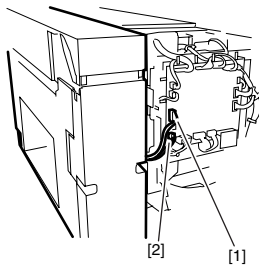

F-3-30

<Saddle Finisher-Q2/R2>

Connect to the connectors J804 [3] and J805 [4] of the saddle drive PCB, and secure the connector cable with two cable clamps [5].

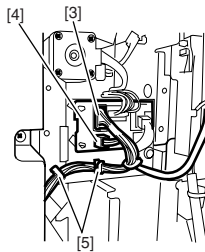

F-3-31

9) In the case of the Finisher-Q1/Q2, attach the rubber sheet [1] that comes with the Buffer Pass Unit-C1 to the puncher unit along the marking [2] found on the right side of the unit.

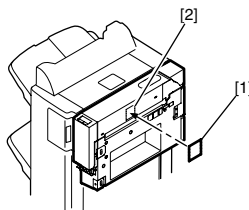

F-3-32

10) In the case of the Finisher-Q1/R1, mount the rear cover of the finisher using 3 screws. In the case of the Saddle Finisher-Q2/R2, mount the rear cover of the finisher using 6 screws; then, attach the cable cover.

11) Mount the upper rear (small) cover of the finisher using a screw.

12) In the case of the Finisher-Q1/R1, mount the

punch lower front cover fixing plate 2 [1] to the finisher using a screw [2] (binding; M4x6). (The figure shows the Finisher-R1.)

Memo: In the case of the Saddle Finisher-Q2/R2, the punch lower front cover fixing plate 2 is mounted at time of shipment from the factory. (It is shaped differently from the punch lower front fixing plate 2 of the Finisher-Q1/R1.)

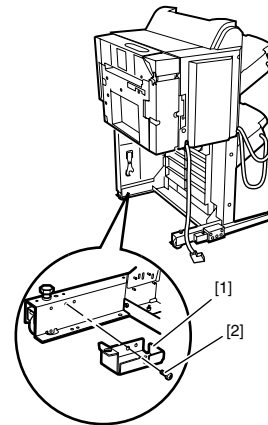

F-3-33

13) In the case of the Saddle Finisher-Q2, mount the lower front extension stay [1] using 2 screws [2] (binding; M4x6). (Skip this step if it has already been mounted.)

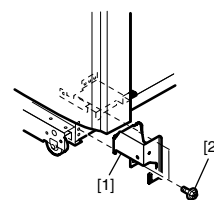

F-3-34

3.3.3 Preparing the Host

Machine for Installation 0003-0208

⚠ Before connecting the finisher to its host machine, mount the fixing plate that comes with the puncher unit to the host machine. If the host machine has

already been installed and the finisher has been disconnected from it as instructed in "Disconnecting the Finisher from the Host Machine," go to step 3).

1) Cut off the surface cover from the left cover of the host machine.

<Finisher-Q1/Q2>

Remove the 4 screws [1], and detach the left cover [2] of the host machine; then, cut off the 2 surface covers [3] and [4] using nippers. Cut off the surface cover [6] from the rear left cover [5] using nippers; then, mount the left cover.

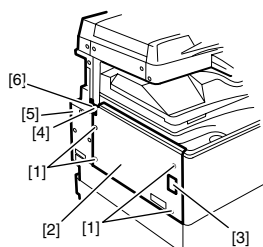

F-3-35

<Finisher-R1/R2>

Remove the 3 screws [1], and detach the left cover [2] of the host machine. Cut off the 2 surface covers [3] from the left cover; then, mount the left cover to the machine.

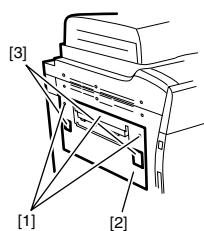

F-3-36

2) In the case of the Finisher-R1/R2, slide the inlet guides upper [1] and lower [2] along the delivery assembly of the host machine, and fix them in place using screws [3] (1 pc. each; tapping; M4x12).

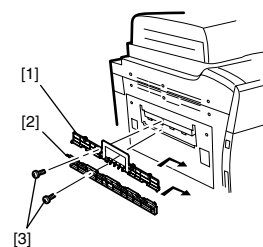

F-3-37

3) Mount the front fixing plate [1] and the rear fixing plate [2] in place using 2 screws [3] each (binding; M4x6).

<Finisher-Q1/Q2>

Use FC5-4098 as the fixing plate [1] and FC5-4076 as the fixing plate [2]. (They come with the puncher unit.)

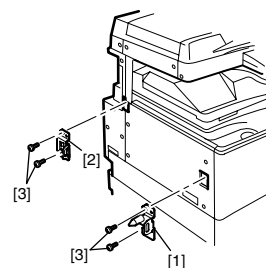

F-3-38

<Finisher-R1/R2>

Use FC5-4098 as the fixing plate [1] and FC5-4076 as the fixing plate [2]. (They come with the puncher unit.)

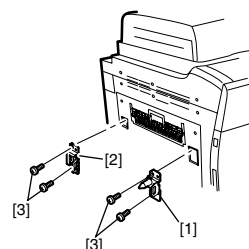

F-3-39

3.3.4 Connecting to the Host Machine

0003-0209

⚠ Check to make sure that the host machine is off and its power plug is disconnected from the power outlet.

1) Remove the 3 screws [1], and detach the rear cover [2] of the puncher unit.

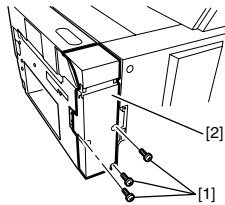

F-3-40

2) In the case of the Finisher-Q1/Q2, mount the included surface cover [1].

3) Connect the puncher unit to its host machine, and secure the fixing plates (front and rear) using a screw [2] (1 pc. each; stepped; M4).

<Finisher-Q1/Q2>

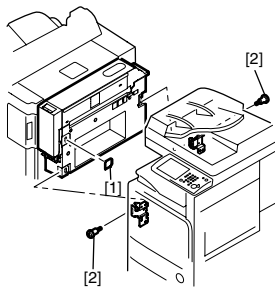

F-3-41

<Finisher-R1/R2>

Secure the front fixing plate in place using a stepped screw after opening the punch front cover [3].

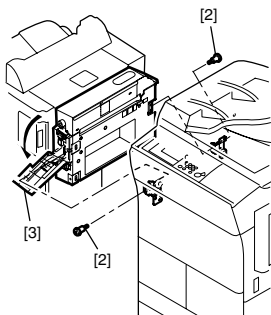

F-3-42

4) Mount the rear cover of the puncher unit using 3 screws.

5) Mount the punch lower front cover fixing plate 1 [1] to the punch lower front cover [2] using a screw [3] (tapping; M4x12).

6) In the case of the Finisher-Q1/Q2, mount the punch front lower extension cover [4] to the punch lower front cover using a screw [3] (tapping; M4x12).

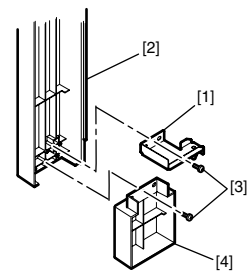

F-3-43

7) Fit the positioning pin [1] into the hole of the punch lower front cover fixing plate 2 [2] to mount the punch lower front cover. (The figure shows the Finisher-R1.)

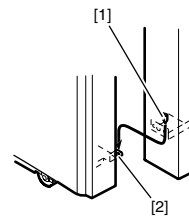

F-3-44

8) Open the punch upper front cover [1], and secure the punch lower front cover [2] from above using a screw [3] (tapping; M4x12). (The figure shows the Finisher-Q1.)

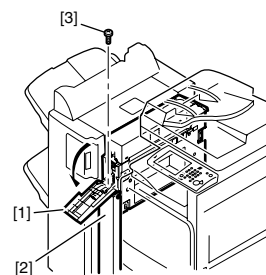

F-3-45

3.3.5 Checking the Height/

Tilt

0003-0210

⚠ A finisher may already exist and the height/tilt may have been adjusted in relation to the host machine. You may still have to adjust the height/tilt newly to make up for changes that may have occurred because of the installation of the puncher unit. If the height/tilt is not correct, jams can occur frequently in the puncher unit pickup assembly. When you have installed the puncher unit, be sure to go through the following steps to check and adjust the height/tilt.

1) Check the height of the puncher unit and its host machine.

<Finisher-Q1/Q2>

Place a ruler on the buffer pass unit as shown and check to see if it is as indicated on the right side of the puncher unit (falling between the top and bottom index lines). Check the height at both front and rear by referring to the 2 sets of index lines; be sure that the discrepancy in height is 1.5 mm or less.

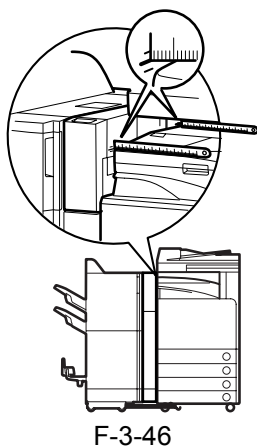

<Finisher-R1/R2>

Check to see if the difference in height between the top cover of the puncher unit and the top edge of the delivery cover of the host machine is 53 ± 2 mm. Take measurements at 2 locations at both front and rear;

then, see if the difference in height between the front and the rear is 1.5 mm or less.

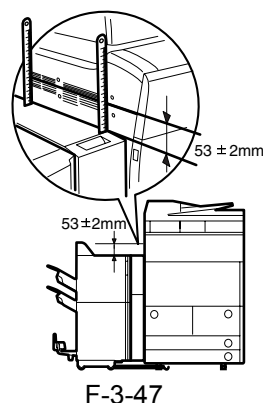

2) Check the tilt of the puncher unit and the host machine.

<Finisher-Q1/Q2>

Check to see if the gap between the top cover of the puncher unit and the delivery cover of the host machine is 3 ± 1.5 mm. Take measurements at 2 locations (front and rear); then, check to see that the difference in the gap between the front and the rear is 1.5 mm or less. Moreover, check to see that the gap running from top to bottom between the finisher and the host machine is parallel when viewed from the front.

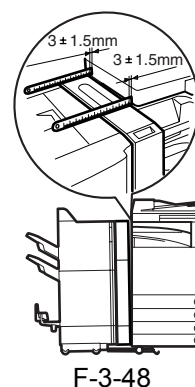

<Finisher-R1/R2>

Check to see that the gap between the upper cover of the puncher unit and the delivery cover of the host machine is 3 ± 1.5 mm or less. Take measurements at 2 locations (front and rear); then, check to be sure that the difference in the gap between the front and the rear

is 1.5 mm or less. Moreover, check to be sure that the gap running from top to bottom between the finisher and host machine is parallel when viewed from the front.

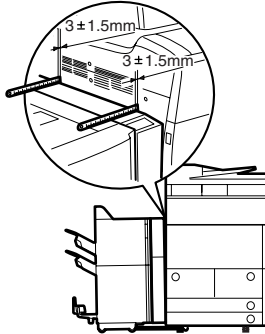

F-3-49

3) If the height/tilt is correct, end the installation work as instructed in "Work After Making Checks/ Adjustments." Otherwise, make adjustments as instructed in "Adjusting the Height/Tilt."

3.4 Making Adjustments

3.4.1 Adjusting the Height/Tilt

0003-0211

⚠ If the difference in height between the puncher unit and the host machine or the tilt is not as indicated, make adjustments as follows; be sure to adjust the height before adjusting the tilt:

A. Preparing for Adjustment

⚠ In the case of the Finisher-Q1/R1, you may need to remove the auxiliary ring and the rear foot cover of the finisher before adjusting the height; be sure to remove the auxiliary ring without disconnecting the finisher from its host machine to prevent the finisher from tumbling over.

<Finisher-Q1/R1>

1) If the height at the rear must be corrected, remove the auxiliary ring and the left rear foot cover.

<Finisher-Q1>

Remove the 4 screws [1], and detach the auxiliary ring [2]. Remove the screw [3], and detach the left rear foot cover [4].

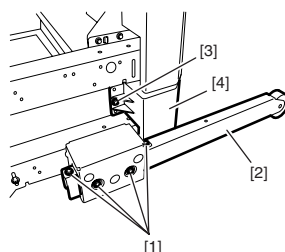

F-3-50

<Finisher-R1>

Remove the 4 screws [1], and detach the auxiliary ring [2]. Remove the 2 screws [3], and detach the left rear foot cover [4].

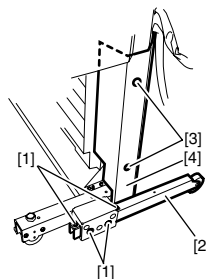

F-3-51

2) Remove the 3 screws, and detach the front cover. (Skip this step if it has already been removed.)

3) From the back of the front cover, remove the fixing screw, and detach the spanners [1].

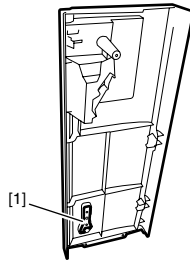

F-3-52

<Saddle Finisher-Q2/R2>

1) Open the front cover; then, from the back of the front cover, remove the fixing screw, and detach the spanners [1]. (The figure shows the Saddle Finisher-Q2.)

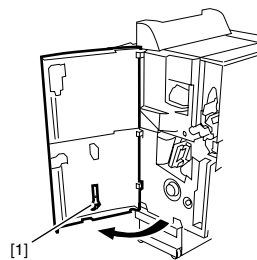

F-3-53

B. Adjusting the Height

1) Loosen the 2 fixing screws [1] each on the front and rear casters on the pickup side of the finisher.

2) To increase the height of the finisher and the puncher unit, turn the adjusting bolt [2] in the direction of the arrow A (A full turn of the adjusting bolt will increase the height of the finisher by 1.75 mm.). Refer to the index while turning the bolt, and perform this for both front and rear casters.

3) To decrease the height of the finisher and the puncher unit, turn the adjusting bolt [2] in the direction of the arrow B (A full turn of the adjusting bolt will decrease the height of the finisher by 1.75 mm.). Refer to the index while turning the bolt, and perform this for both front and rear casters.

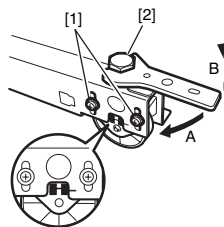

F-3-54

C. Adjusting the Tilt

- 1) Loosen the 2 fixing screws [1] each on the front and rear casters on the delivery side of the finisher.
- 2) To decrease the gap between the punch unit and the host machine, turn the adjusting bolt [2] in the direction of the arrow A (A full turn of the adjusting bolt will increase the height of the finisher by 1.75 mm.). Refer to the index on the caster while turning the bolt, and perform this for both front and rear casters.
- 3) To increase the gap between the puncher unit and the host machine, turn the adjusting bolt [2] in the direction of the arrow B (A full turn of the adjusting bolt will decrease the height of the finisher by 1.75 mm.). Refer to the index on the caster while turning the bolt, and perform this for both front and rear casters.

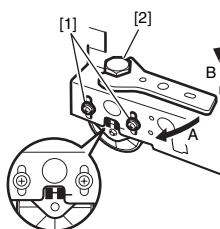

F-3-55

D. Making Checks After Adjustment

- 1) Check to see once again that the difference in height between the finisher and the puncher unit and the tilt are as indicated; otherwise, make adjustments once again.
- 2) When done, tighten the 2 fixing screws [1] each on the casters.
- 3) To prevent the adjusting bolts from becoming loose during transit for possible relocation after installation, tighten the bolts [2] 90 deg in the direction of the arrow. Take care, however; excess tightening will affect the height/tilt.

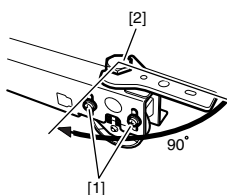

F-3-56

- 4) Attach the spanners to the back of the front cover using a screw.
- 5) End the installation work as instructed in "Work After Making Checks/Adjustments."

3.4.2 Work After Making Checks/Adjustments

0003-0212

<Finisher-Q1/R1>

- 1) If you removed the auxiliary ring, fit the left rear foot cover, adjust the length of the auxiliary rail to suit the needs of the user, and mount it using 4 screws.

2) Mount the front cover to the finisher using 3 screws.

3) Mount the covers.

<Finisher-Q1>

Mount the lower front extension cover [1] using a screw [2] (RS tightening; M3x8). Mount the front foot cover [3] using a screw [2] (RS tightening; M3x8).

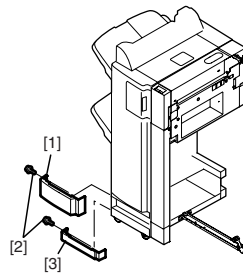

F-3-57

<Finisher-R1>

Mount the front foot cover [1] using a screw [2] (RS tightening; M3x8).

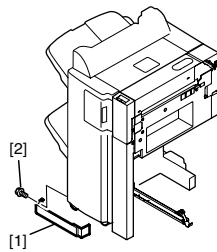

F-3-58

4) Connect the finisher and the host machine using the interface cable [1].

⚠ When connecting the interface cable, be sure to turn off the host machine and disconnect its power plug from the power outlet. Otherwise, you can suffer an electric shock.

<Finisher-Q1>

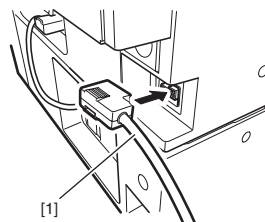

F-3-59

<Finisher-R1>

Fit the cable clamp [2] to the host machine, and route the interface cable [1] through it.

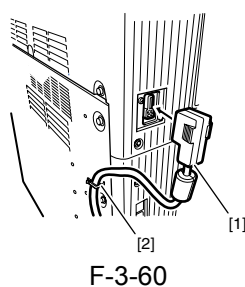

<Saddle Finisher-Q2>

1) Detach the punch lower front cover once; then, remove the front and rear stepped screws (1 pc. each), and separate the puncher unit and the host machine.

2) Mount the lower front extension cover [1] using a screw [2] (RS tightening; M3x8) and another screw [3] (tapping; M4x12).

3) Mount the front foot cover [4] using a screw [2] (RS tightening; M3x8).

4) Mount the rear foot cover [5] using a screw [2] (RS tightening; M3x8).

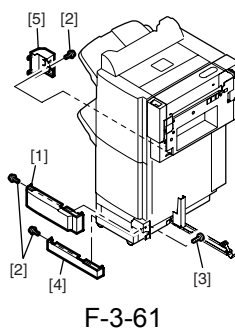

5) Connect the puncher unit and the host machine; then, secure them at the front and the rear using stepped screws (1 pc. each).

6) Mount the punch lower front cover.

7) Connect the finisher and the host machine with the interface cable [1].

⚠ When connecting the interface cable, be sure to turn off the host machine and disconnect its power plug from the power outlet. Otherwise, you can suffer an electric shock.

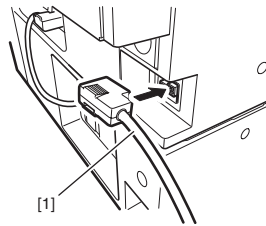

F-3-62

<Saddle Finisher-R2>

- 1) Mount the front foot cover [1] using a screw [2] (RS tightening; M3x8).
- 2) Align the rear foot cover claw [3] with the rear cover and mount the rear foot cover [4] with a screw (tapping; M4x12) [5].

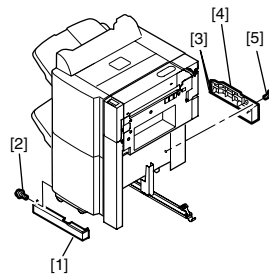

F-3-63

- 3) Connect the finisher and the host machine with the interface cable [1]. Fit the cable clamp [2] to the host machine, and route the interface cable [1] through it.

⚠ When connecting the interface cable, be sure to turn off the host machine and disconnect its power plug. Otherwise, you may suffer an electric shock.

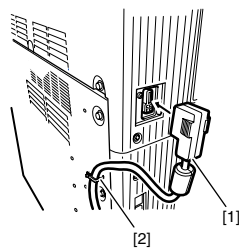

F-3-64

3.5 Attaching the Labels etc.

3.5.1 Attaching the Label

0003-0213

1) Open the front cover of the puncher unit, and attach the Jam Removal label [1] of the appropriate language where indicated. (The figure shows the Finisher-Q1.)

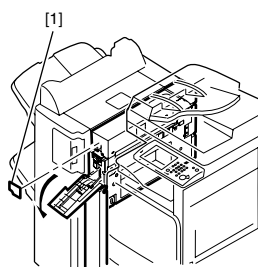

F-3-65

Chapter 4 Parts

Replacement Procedure

Contents

4.1 External Covers	4-1
4.1.1 Rear Cover	4-1
4.1.1.1 Removing the Rear Cover	4-1
4.1.2 Upper Cover	4-1
4.1.2.1 Removing the Rear Cover	4-1
4.1.2.2 Removing the Upper Cover	4-1
4.1.3 Right Guide Unit	4-1
4.1.3.1 Removing the Right Guide Unit	4-1
4.2 Drive System	4-2
4.2.1 Punch Motor	4-2
4.2.1.1 Removing the Rear Cover	4-2
4.2.1.2 Removing the Upper Cover	4-2
4.2.1.3 Removing the Punch Motor	4-2
4.2.2 Horizontal Registration Motor	4-2
4.2.2.1 Removing the Rear Cover	4-2
4.2.2.2 Removing the Right Guide Unit	4-3
4.2.2.3 Removing the Horizontal Registration Motor	4-3
4.2.3 Punch Unit	4-3
4.2.3.1 Notification when dismantling the Punch Unit	4-3
4.2.3.2 Removing the Rear Cover	4-3
4.2.3.3 Removing the Right Guide Unit	4-4
4.2.3.4 Removing the Upper Cover	4-4
4.2.3.5 Removing the Punch Unit	4-4
4.3 Electrical System	4-7
4.3.1 Punch Unit Harness	4-7
4.3.1.1 Notification when dismantling the Punch Unit Harness	4-7
4.3.1.2 Removing the Rear Cover	4-7
4.3.1.3 Removing the Right Guide Unit	4-7
4.3.1.4 Removing the Upper Cover	4-7
4.3.1.5 Removing the Punch Unit Harness	4-7
4.3.1.6 Installing the Punch Unit Harness	4-9
4.3.2 LED PCB	4-9
4.3.2.1 Removing the Rear Cover	4-9
4.3.2.2 Removing the Right Guide Unit	4-10
4.3.2.3 Removing the Upper Cover	4-10
4.3.2.4 Removing the Punch Unit	4-10
4.3.2.5 Removing the LED PCB	4-12
4.3.3 Photosensor PCB	4-12
4.3.3.1 Removing the Rear Cover	4-12
4.3.3.2 Removing the Upper Cover	4-13
4.3.3.3 Removing the Photosensor PCB	4-13
4.3.4 Scrap Full Detector PCB	4-13
4.3.4.1 Removing the Right Guide Unit	4-13
4.3.4.2 Removing the Scrap Full Detector PCB	4-13

4.3.5 Punch Controller PCB	4-14
4.3.5.1 Removing the Rear Cover.....	4-14
4.3.5.2 Removing the Punch Controller PCB.....	4-14

4.1 External Covers

4.1.1 Rear Cover

4.1.1.1 Removing the Rear Cover

0003-6789

- 1) Remove three screws [1] and remove the rear cover [2].

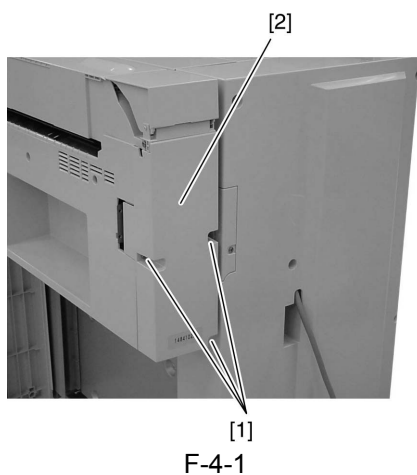

4.1.2 Upper Cover

4.1.2.1 Removing the Rear Cover

0003-6790

- 1) Remove three screws [1] and remove the rear cover [2].

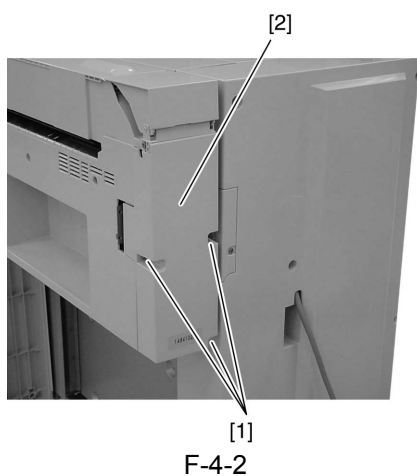

4.1.2.2 Removing the Upper Cover

0003-6791

- 1) Open the front door [1], remove three screws [2], and remove the upper cover [3].

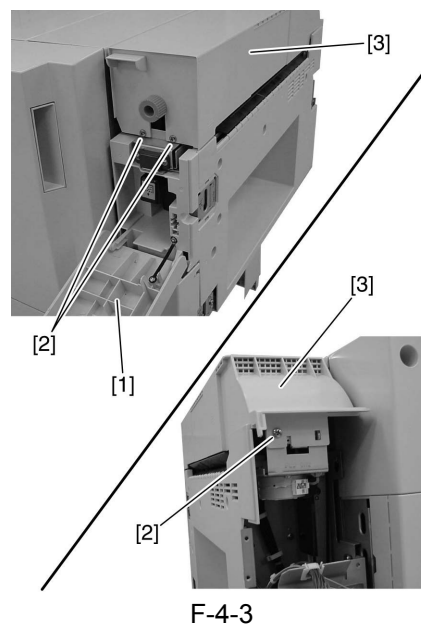

4.1.3 Right Guide Unit

4.1.3.1 Removing the Right Guide Unit

0003-6792

- 1) Remove four screws [1], and remove the right guide assembly [2].

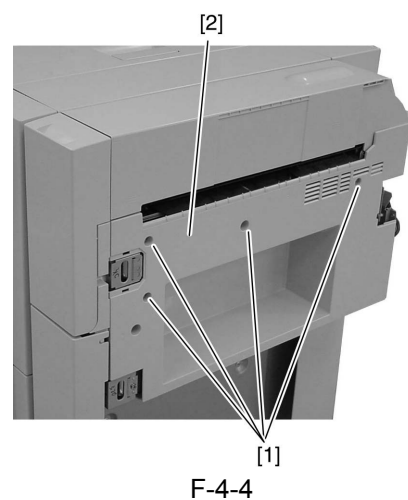

4.2 Drive System

4.2.1 Punch Motor

4.2.1.1 Removing the Rear Cover

0003-6793

- 1) Remove three screws [1] and remove the rear cover [2].

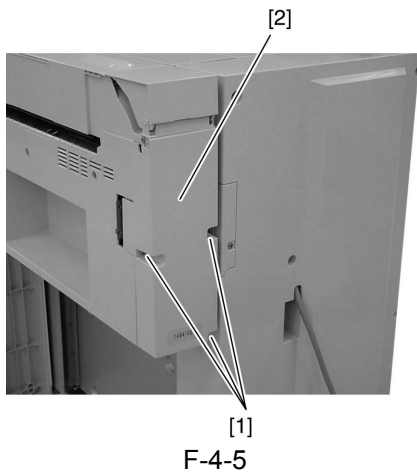

4.2.1.2 Removing the Upper Cover

0003-6794

- 1) Open the front door [1], remove three screws [2], and remove the upper cover [3].

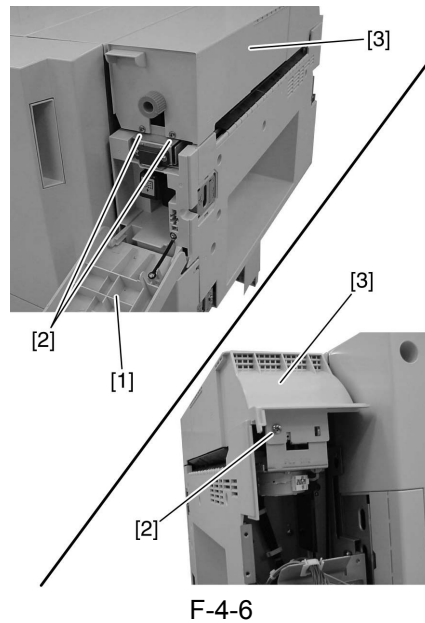

4.2.1.3 Removing the Punch Motor

0003-6795

- 1) Disconnect the connector [1].
- 2) Remove two screws [2] and remove the punch motor [3].

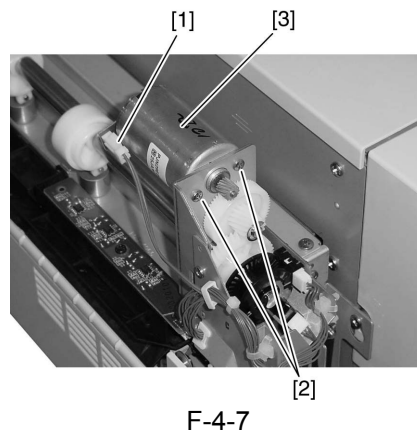

4.2.2 Horizontal Registration Motor

4.2.2.1 Removing the Rear Cover

0003-6796

- 1) Remove three screws [1] and remove the rear cover [2].

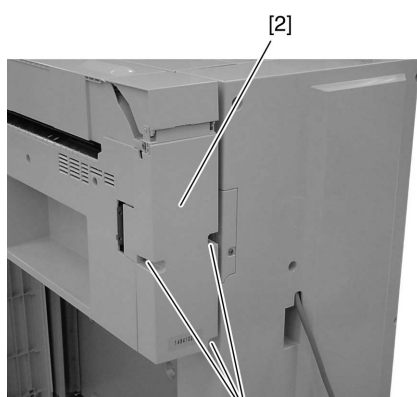

F-4-8

4.2.2.2 Removing the Right Guide Unit

0003-6797

- 1) Remove four screws [1], and remove the right guide assembly [2].

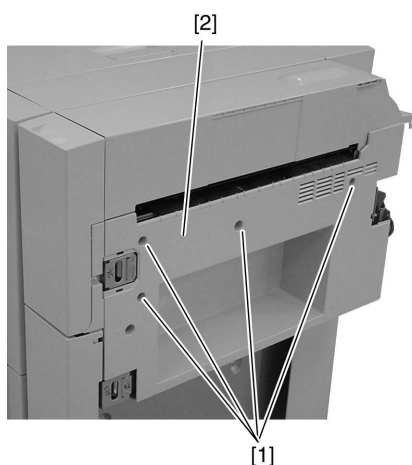

F-4-9

4.2.2.3 Removing the Horizontal Registration Motor

0003-6798

- 1) Disconnect the connector [1].
- 2) Remove two screws [2] and slide the horizontal registration motor [3] in the direction of the arrow to remove.

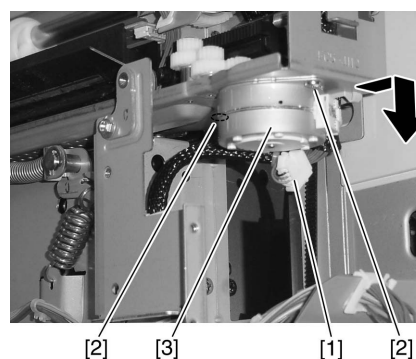

F-4-10

4.2.3 Punch Unit

4.2.3.1 Notification when dismounting the Punch Unit

0003-8233

- ⚠** When removing the punch unit, the punch unit section sometimes opens. If necessary, perform work with the punch unit section in an open state.

4.2.3.2 Removing the Rear Cover

0003-6800

- 1) Remove three screws [1] and remove the rear cover [2].

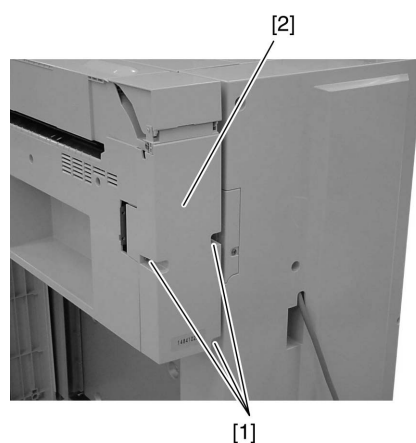

F-4-11

4.2.3.3 Removing the Right Guide Unit

0003-6799

1) Remove four screws [1], and remove the right guide assembly [2].

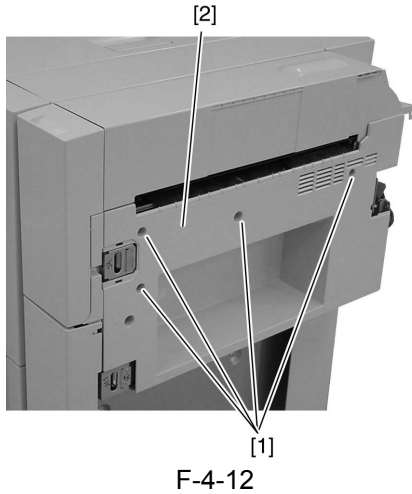

4.2.3.4 Removing the Upper Cover

0003-6801

1) Open the front door [1], remove three screws [2], and remove the upper cover [3].

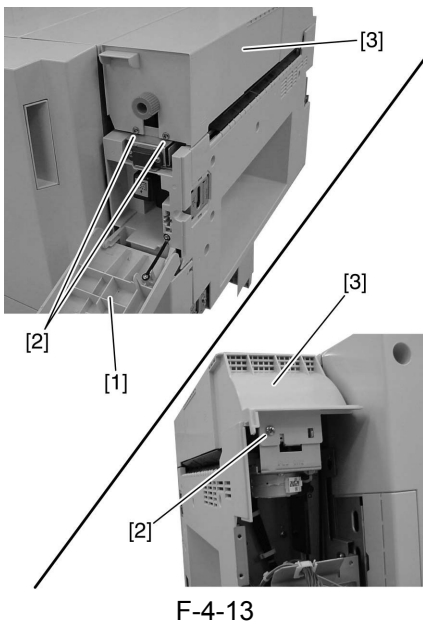

4.2.3.5 Removing the Punch Unit

0003-6802

1) Remove E-ring [1], washer [2], and puncher spring [3].

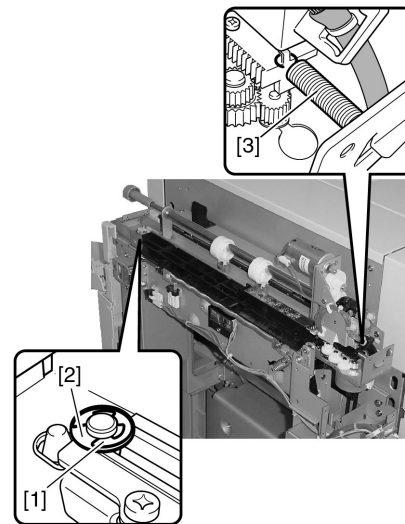

2) Turn the gear [1] in the direction of the arrow, and move the punch unit section [2] to the front side.

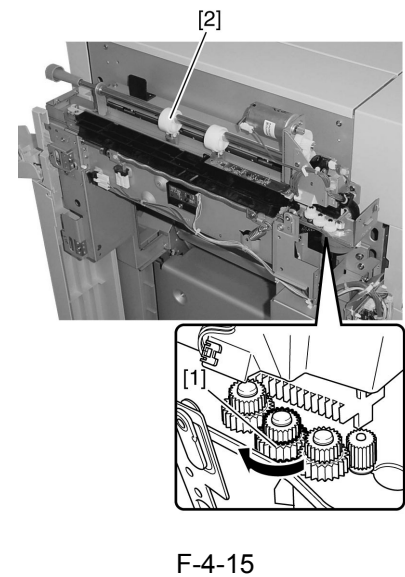

3) Remove the three screws [1], and remove the sensor mount (upper) [2]. Then, remove the connector [3] on the photosensor PCB.

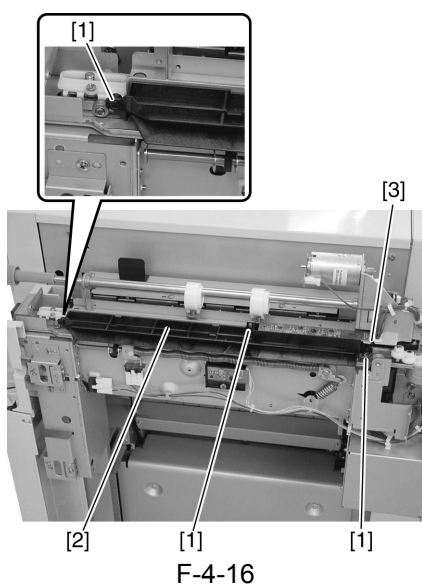

F-4-16

4) Disconnect the connector [1] and remove the screw [2], and remove the horizontal registration home position sensor [3].

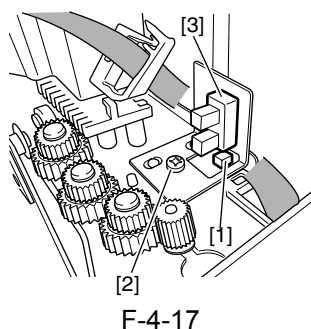

F-4-17

5) Turn the gear [1] in the direction of the arrow, and move the punch unit section [2] to the far side.

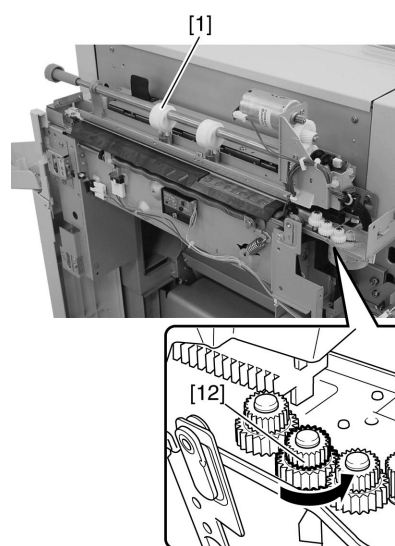

F-4-18

6) Remove the tie wrap with lock [1] while holding its claw between your fingers. (The tie wrap must be removed without being cut.)

7) Disconnect the three connectors [2] and remove the screw [3], and remove the harness guide [4].

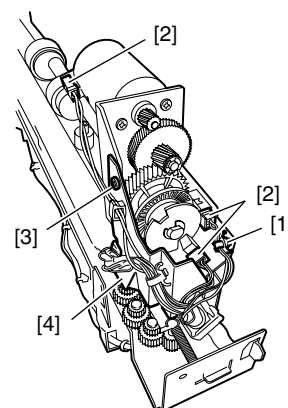

F-4-19

8) Lift up the front side of the punch unit section [1] first, then move in the direction of the arrow to remove the punch unit section [1].

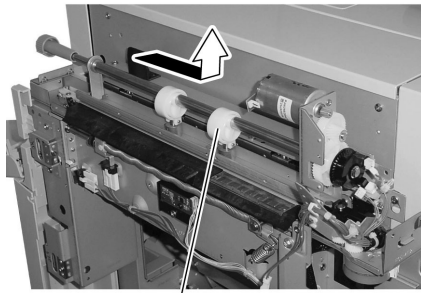

[1]
F-4-20

9) Disconnect the connector [1] on LED PCB.

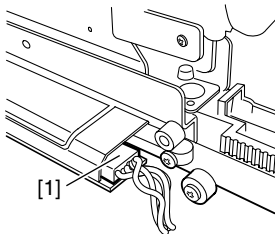

F-4-21

10) Remove the slide shaft support [1], the sensor mount (lower) [2] and the puncher knob [3] from the punch unit section.

⚠ The slide shaft support [1] is not attached to punch unit section that are currently set as service parts. When replacing the punch unit section, be sure to attach the slide shaft support that was in use beforehand. If you forget to attach the slide shaft support, the machine may malfunction.

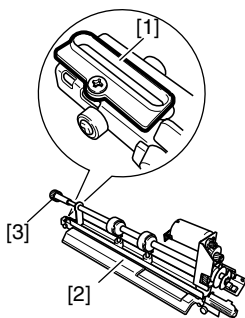

F-4-22

4.3 Electrical System

4.3.1 Punch Unit Harness

4.3.1.1 Notification when dismounting the Punch Unit Harness

0003-8728

⚠ When removing the punch unit, the punch unit section sometimes opens. If necessary, perform work with the punch unit section in an open state.

4.3.1.2 Removing the Rear Cover

0003-6804

1) Remove three screws [1] and remove the rear cover [2].

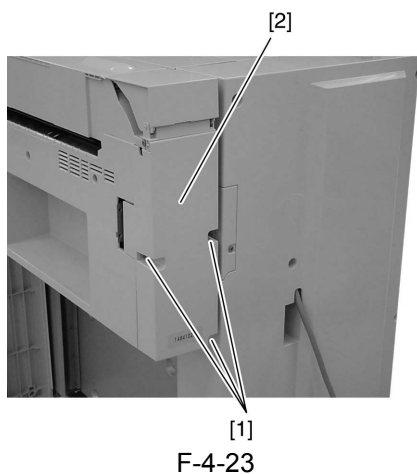

4.3.1.3 Removing the Right Guide Unit

0003-6805

1) Remove four screws [1], and remove the right guide assembly [2].

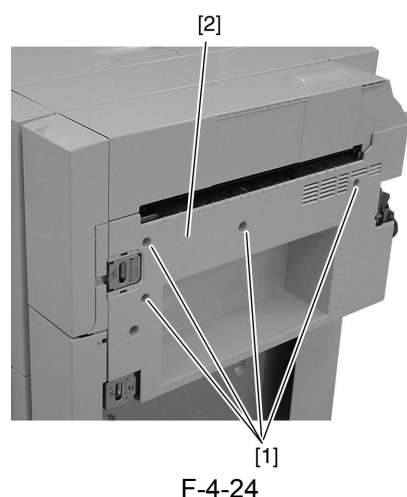

4.3.1.4 Removing the Upper Cover

0003-6803

1) Open the front door [1], remove three screws [2], and remove the upper cover [3].

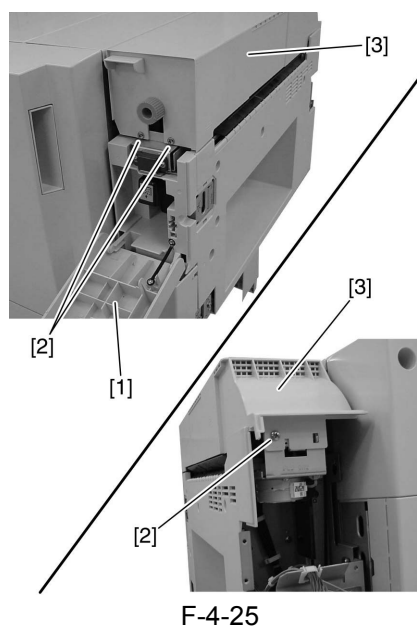

4.3.1.5 Removing the Punch Unit Harness

0003-6807

1) Disconnect the two connectors [2] on the punch controller PCB [1] and remove the harness from the edge saddle [3].

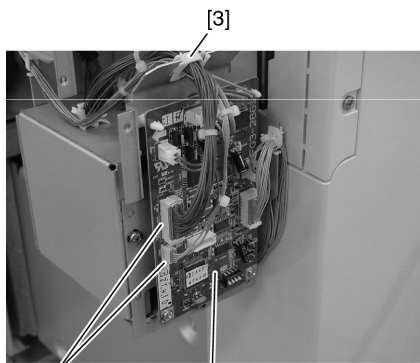

F-4-26

- 2) Remove the two tie wraps with lock [1] while holding its claw between your fingers. (The tie wraps must be removed without being cut.)
- 3) Disconnect the three connectors [2].
- 4) Free the harness [4] from the three harness stops [3].

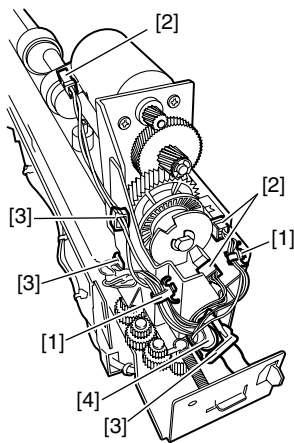

F-4-27

- 5) Turn the gear [1] in the direction of the arrow, and move the punch unit section [2] to the front side.

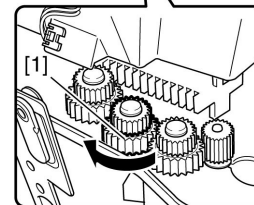
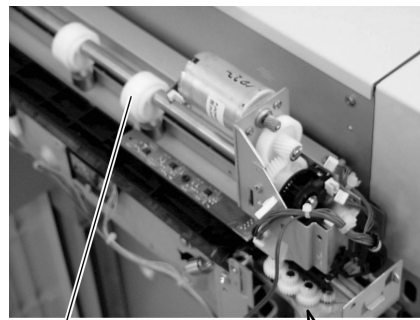

F-4-28

- 6) Remove the three screws [1] and sensor mount (upper) [2].
- 7) Disconnect the connector [3] on the photosensor PCB and the connector [4] on the LED PCB and remove the harness from the edge saddle [5].

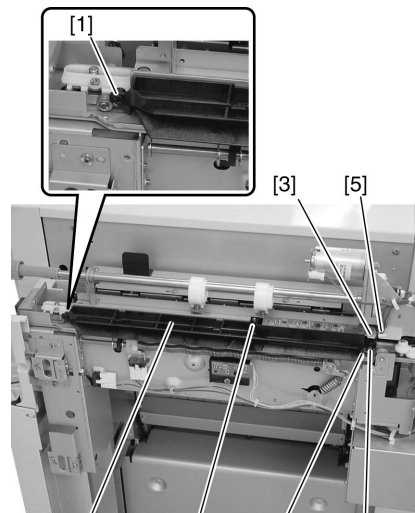

F-4-29

- 8) Free the harness [2] from the four harness stops [1].

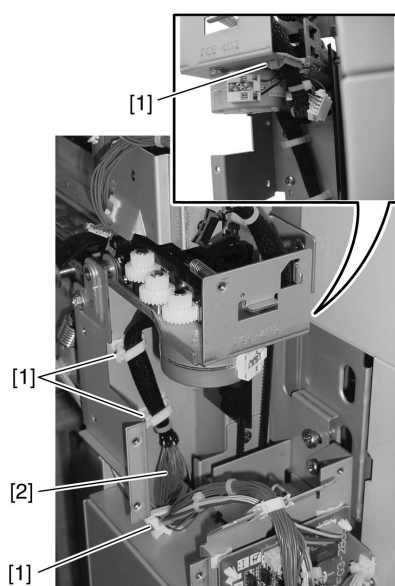

F-4-30

9) Disconnect the connector [1] of the horizontal registration motor and the connector [2] of the horizontal registration home position sensor, and remove the punch unit harness.

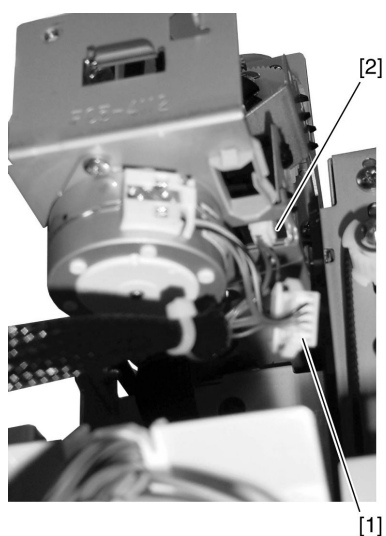

F-4-31

4.3.1.6 Installing the Punch Unit Harness

0003-6806

⚠ Offset punch unit harnesses can cause malfunction. The punch unit harnesses must be

firmly installed at the positions described below.

1) Fasten the punch unit harnesses so that the two tie wraps [1] of the punch unit harnesses are on the outside of the two respective clamps [2].

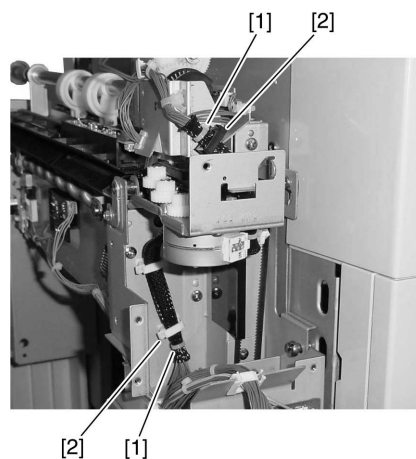

F-4-32

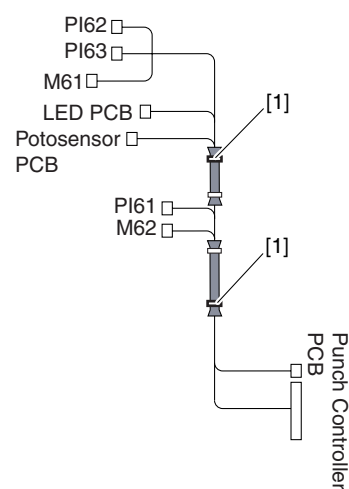

F-4-33

4.3.2 LED PCB

4.3.2.1 Removing the Rear Cover

0003-6809

1) Remove three screws [1] and remove the rear cover [2].

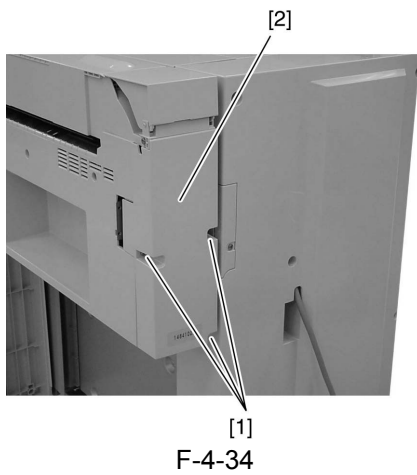

4.3.2.2 Removing the Right Guide Unit

0004-0830

1) Remove four screws [1], and remove the right guide assembly [2].

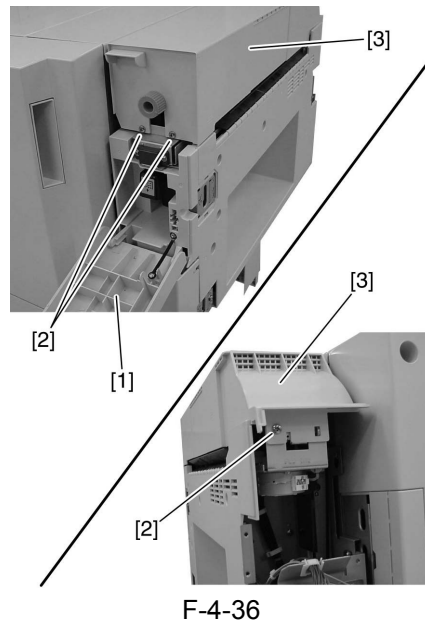

4.3.2.4 Removing the Punch Unit

0004-0831

1) Remove E-ring [1], washer [2], and puncher spring [3].

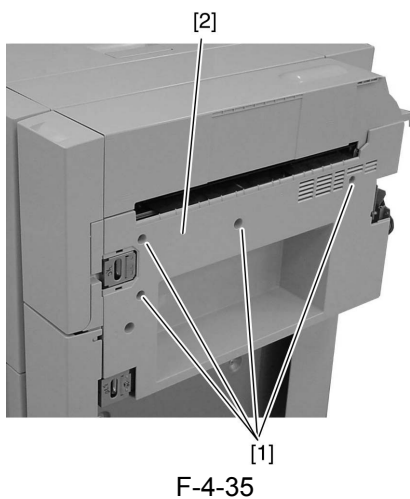

4.3.2.3 Removing the Upper Cover

0003-6810

1) Open the front door [1], remove three screws [2], and remove the upper cover [3].

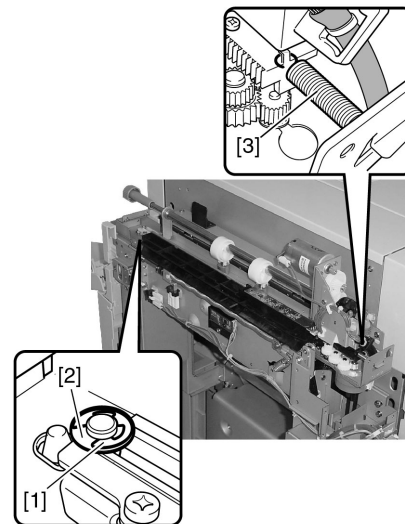

2) Turn the gear [1] in the direction of the arrow, and move the punch unit section [2] to the front side.

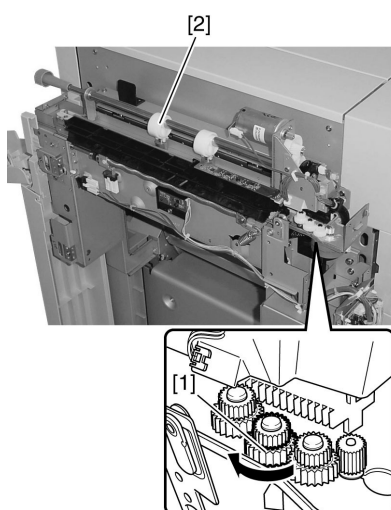

F-4-38

3) Remove the three screws [1], and remove the sensor mount (upper) [2]. Then, remove the connector [3] on the photosensor PCB.

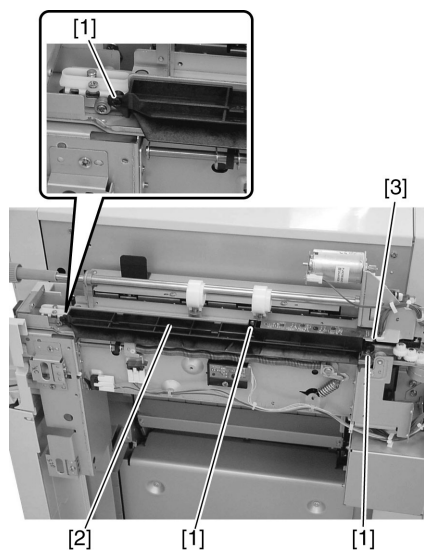

F-4-39

4) Disconnect the connector [1] and remove the screw [2], and remove the horizontal registration home position sensor [3].

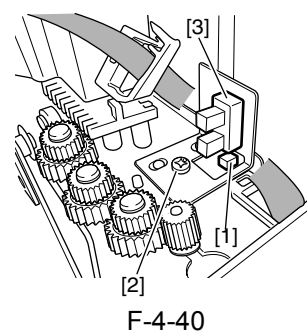

F-4-40

5) Turn the gear [1] in the direction of the arrow, and move the punch unit section [2] to the far side.

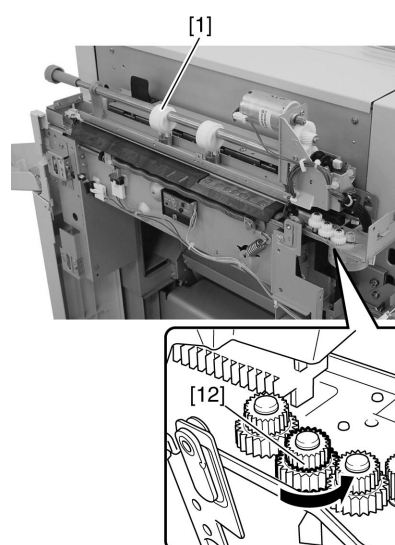

F-4-41

6) Remove the tie wrap with lock [1] while holding its claw between your fingers. (The tie wrap must be removed without being cut.)

7) Disconnect the three connectors [2] and remove the screw [3], and remove the harness guide [4].

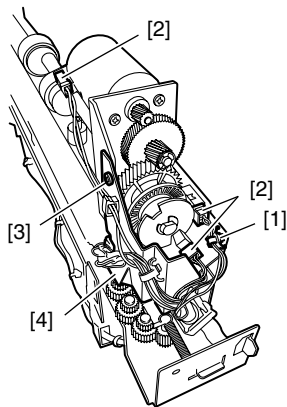

F-4-42

8) Lift up the front side of the punch unit section [1] first, then move in the direction of the arrow to remove the punch unit section [1].

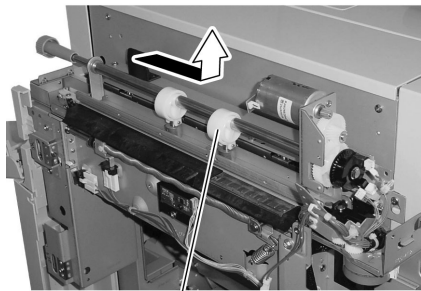

[1]
F-4-43

9) Disconnect the connector [1] on LED PCB.

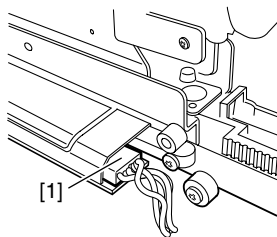

F-4-44

10) Remove the slide shaft support [1], the sensor mount (lower) [2] and the puncher knob [3] from the punch unit section.

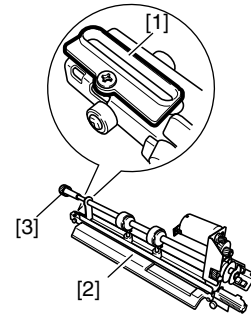

F-4-45

unit section that are currently set as service parts. When replacing the punch unit section, be sure to attach the slide shaft support that was in use beforehand. If you forget to attach the slide shaft support, the machine may malfunction.

4.3.2.5 Removing the LED PCB

0004-0827

1) Remove the screw [1], and remove the LED PCB [2].

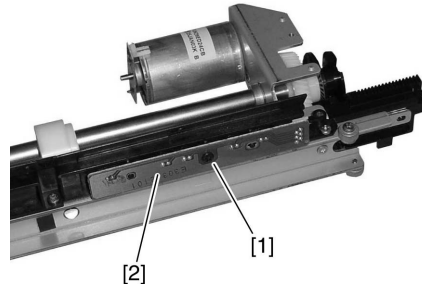

F-4-46

4.3.3 Photosensor PCB

4.3.3.1 Removing the Rear Cover

0003-6813

1) Remove three screws [1] and remove the rear cover [2].

⚠ The slide shaft support [1] is not attached to punch

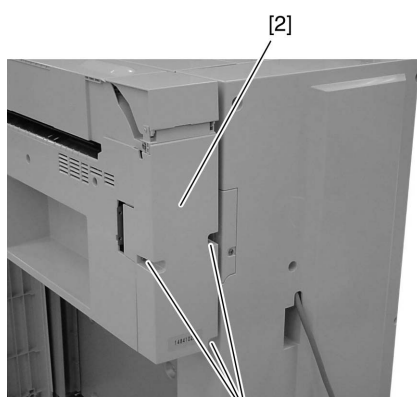

F-4-47

4.3.3.2 Removing the Upper Cover

0003-6812

- 1) Open the front door [1], remove three screws [2], and remove the upper cover [3].

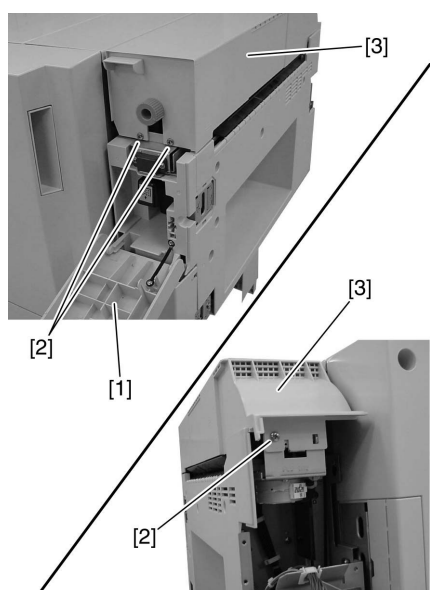

F-4-48

4.3.3.3 Removing the Photosensor PCB

0004-0829

- 1) Remove the screw [1].
- 2) Disconnect the connector [2] and the remove the Photosensor PCB [3].

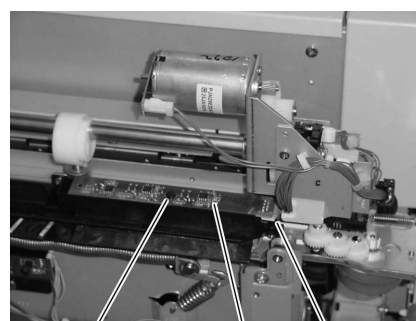

F-4-49

4.3.4 Scrap Full Detector PCB

4.3.4.1 Removing the Right Guide Unit

0003-6817

- 1) Remove four screws [1], and remove the right guide assembly [2].

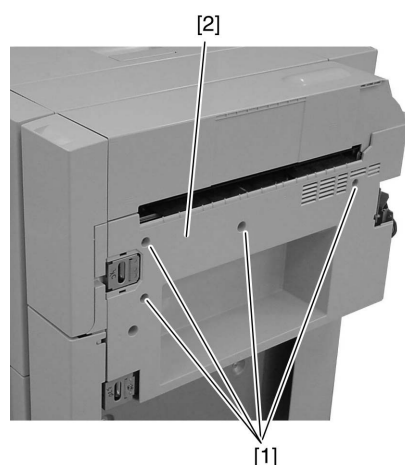

F-4-50

4.3.4.2 Removing the Scrap Full Detector PCB

0003-6818

- 1) Remove the screw [1], disconnect the connector [2], and remove the scrap full detector PCB unit [3].

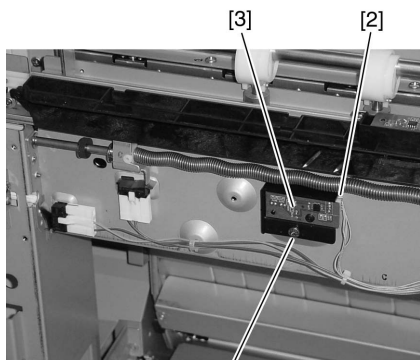

F-4-51

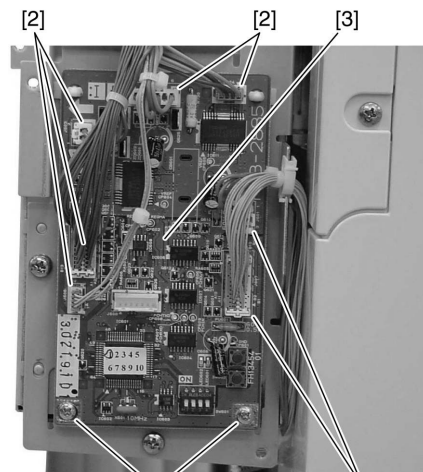

F-4-53

4.3.5 Punch Controller PCB

4.3.5.1 Removing the Rear

Cover

0003-6819

- 1) Remove three screws [1] and remove the rear cover [2].

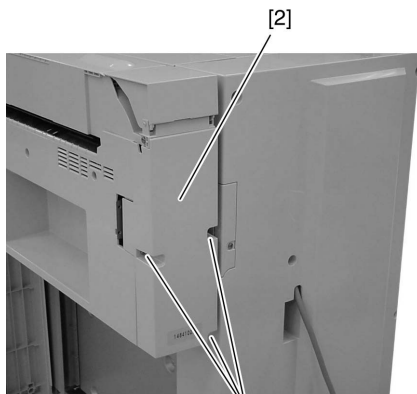

F-4-52

4.3.5.2 Removing the Punch

Controller PCB

0003-6820

- 1) Remove the two screws [1], disconnect seven connectors [2], and remove the punch controller PCB [3].

Chapter 5 Maintenance

Contents

5.1 User Maintenance	5-1
5.1.1 User Maintenance	5-1
5.2 Maintenance and Inspection	5-2
5.2.1 Periodically Replaced Parts	5-2
5.2.1.1 Periodically Replaced Parts	5-2
5.2.2 Durables	5-2
5.2.2.1 Durables	5-2
5.2.3 Periodical Servicing	5-2
5.2.3.1 Periodical Servicing	5-2
5.3 Adjustment	5-3
5.3.1 Adjustment at Time of Parts Replacement	5-3
5.3.1.1 Adjusting the Punch Hole Position (feed direction)	5-3
5.3.1.2 Sensor Output Adjustment	5-3
5.3.1.3 Registering the Number of Punch Holes	5-3
5.4 Troubleshooting	5-5
5.4.1 Error Code	5-5
5.4.1.1 E503; Puncher unit communication error	5-5
5.4.1.2 E505; Backup RAM error	5-5
5.4.1.3 E590; Punch motor error	5-5
5.4.1.4 E591; Scrap full detector sensor error	5-6
5.4.1.5 E592; Trailing edge/Horizontal registration sensor error	5-6
5.4.1.6 E593; Horizontal registration motor error	5-6
5.5 Outline of Electrical Components	5-7
5.5.1 Sensors	5-7
5.5.2 Microswitches	5-8
5.5.3 Motors	5-9
5.5.4 PCBs	5-10
5.6 Variable Resistors (VR), Light-Emitting Diodes (LED), and Check Pins by PCB	5-12
5.6.1 Overview	5-12
5.6.2 Punch Controller PCB	5-12
5.7 Upgrading	5-13
5.7.1 Upgrading	5-13
5.8 Service Tools	5-21
5.8.1 Solvents and Oils	5-21

5.1 User Maintenance

5.1.1 User Maintenance

0003-4705

T-5-1

No.	Item	Timing
1	Punch waste removal	When prompted (indicator on host machine control panel)

5.2 Maintenance and Inspection

5.2.1 Periodically Replaced Parts

5.2.1.1 Periodically Replaced Parts

0003-4706

The Puncher unit does not have parts that must be replaced on a periodical basis.

5.2.2 Durables

5.2.2.1 Durables

0003-4707

There are no durables that require durables.

5.2.3 Periodical Servicing

5.2.3.1 Periodical Servicing

0003-4708

T-5-2

Item	Interval	Description	Remark
Transmittance sensor	25 million sheets	Cleaning	Wipe with dry cloth

5.3 Adjustment

5.3.1 Adjustment at Time of Parts Replacement

5.3.1.1 Adjusting the Punch

Hole Position (feed direction) 0003-4709

This adjustment is possible only with the host machine service mode.

5.3.1.2 Sensor Output

Adjustment 0003-4710

Perform this adjustment when replacing the punch controller PCB, transmittance sensor (photosensor PCB/LED PCB), or deflection sensor (scrap full detector PCB unit).

- 1) Check that the power of the host machine is off and then remove the rear cover of the puncher.
- 2) Set SW601 on the punch controller PCB as shown below.

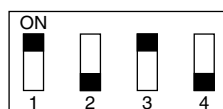

F-5-1

- 3) Turn on the power of the host machine.
- 4) Press SW602 on the punch controller PCB. Sensor output is adjusted automatically when the switch is pressed.

Adjustment is complete if LED601 and 602 on the punch controller PCB flashes alternately.

- 5) Press SW602 or 603 on the punch controller PCB to end the adjustment mode and set all bits of SW601 to OFF.

- 6) Turn off the power of the host machine.

5.3.1.3 Registering the Number of Punch Holes

0003-4711

This operation registers which puncher unit is

attached to the IC on the punch driver PCB so that the puncher unit can be identified by the finisher. For this reason, this operation must be performed when the punch driver PCB has been replaced.

- 1) Check that the power of the host machine is off and then remove the rear cover of the puncher.
- 2) Set SW601 on the punch controller PCB as shown below.



F-5-2

- 3) Turn on the power of the host machine.
- 4) Press SW602 on the punch controller PCB to select the number of punch holes.

The items in the following table are displayed repeatedly from top to bottom each time SW602 is pressed.

T-5-3

Number of punch holes	LED601/602
2 hole(Puncher Unit-L1)	Flash 1 times per cycle
2/3 hole(Puncher Unit-M1)	Flash 2 times per cycle
4 hole(Puncher Unit-N1(FRA))	Flash 3 times per cycle
4 hole(Puncher Unit-P1(SWD))	Flash 4 times per cycle

5) Press SW603 on the punch controller PCB. The number of punch holes is registered to the punch controller PCB each time the switch is pressed.

Registration is complete if LED601 and 602 on the punch controller PCB flashes alternately.

6) Press SW602 or 603 on the punch controller PCB to end the adjustment mode and set all bits of SW601 to OFF.

7) Turn off the power of the host machine.

5.4 Troubleshooting

5.4.1 Error Code

5.4.1.1 E503; Puncher unit communication error

0003-4712

<Finisher controller PCB/Punch controller PCB>

1) Does it improve when the host machine power switch is turned OFF/ON?

YES : End

<Wiring>

2) Is the wiring between the finisher controller PCB and punch controller PCB normal?

NO : Repair the wiring.

<Finisher controller PCB/Punch controller PCB>

3) Does it improve when the finisher controller PCB and punch controller PCB are replaced?

YES : End

5.4.1.2 E505; Backup RAM error

0003-4713

<Punch controller PCB>

1) Does it improve when the host machine power switch is turned OFF/ON?

YES : End

No : Replace the punch controller PCB.

5.4.1.3 E590; Punch motor error

0003-4714

<Punch home position sensor (PI63)>

1) Check the punch home position sensor. Does the sensor operate normally?

NO : Replace the sensor.

<Punch motor clock sensor (PI62)>

2) Check the punch motor clock sensor. Does the sensor operate normally?

NO : Replace the sensor.

<Wiring>

3) Is the wiring between the punch controller PCB and sensors normal?

NO : Repair the wiring.

<Punch mechanism/Punch motor (M61)>

4) Is there any abnormality in the punch mechanism?

YES : Repair the punch mechanism.

NO : Replace the punch motor.

<Punch controller PCB/Finisher controller PCB>

5) Does it improve when the punch controller PCB is replaced?

YES : End

NO : Replace the finisher controller PCB.

5.4.1.4 E591; Scrap full detector sensor error

0003-8758

<Wiring>

1) Is the wiring between the scrap full detector PCB and the punch controller PCB normal?

NO : Repair the wiring.

<Scrap full detector PCB>

2) Does it improve when the scrap full detector PCB is replaced?

YES : End

NO : Replace the punch controller PCB.

<Punch controller PCB/Finisher controller PCB>

3) Does it improve when the punch controller PCB is replaced?

YES : End

NO : Replace the finisher controller PCB.

5.4.1.5 E592; Trailing edge/Horizontal registration sensor error

0003-8760

<Wiring>

1) Is the wiring between the LED PCB/photosensor PCB and the punch controller PCB normal?

NO : Repair the wiring.

<LED PCB/Photosensor PCB>

2) Does it improve when the LED PCB/photosensor PCB is replaced?

YES : End

NO : Replace the punch controller PCB.

<Punch controller PCB/Finisher controller PCB>

3) Does it improve when the punch controller PCB is replaced?

YES : End

NO : Replace the finisher controller PCB.

5.4.1.6 E593; Horizontal registration motor error

0003-4715

<Horizontal registration home position sensor (PI61)>

1) Check the horizontal registration home position sensor. Does the sensor operate normally?

NO : Replace the sensor.

<Wiring>

2) Is the wiring between the punch controller PCB and the sensor normal?

NO : Repair the wiring.

<Horizontal registration mechanism/ Horizontal registration motor (M62)>

3) Is there any abnormality in the horizontal registration mechanism?

YES : Repair the horizontal registration mechanism.

NO : Replace the horizontal registration motor.

<Punch controller PCB/Finisher controller PCB>

4) Does it improve when the punch controller PCB is replaced?

YES : End

NO : Replace the finisher controller PCB.

5.5 Outline of Electrical Components

5.5.1 Sensors

0005-8426

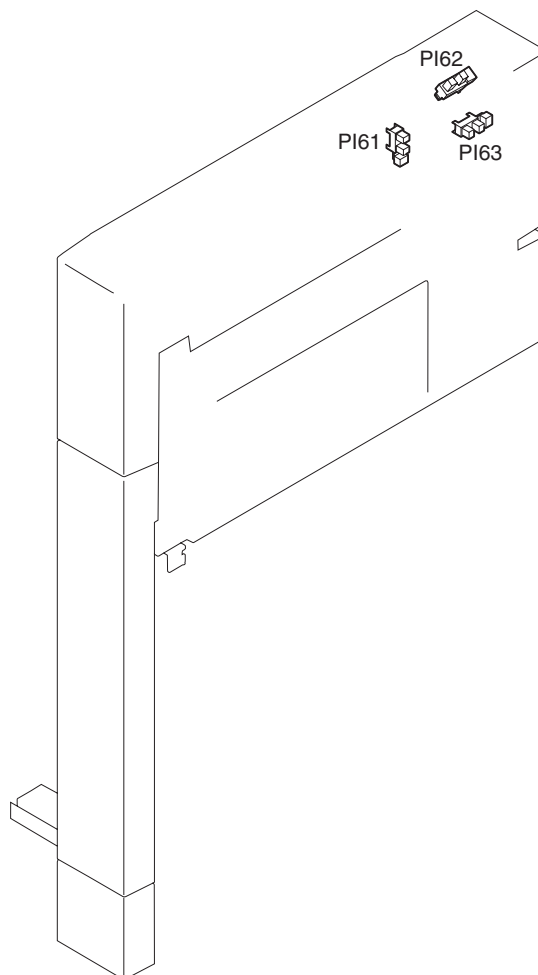

F-5-3

T-5-4

Ref.	Name	Parts number	Punch controller PCB	JAM	Error
PI61	Horizontal registration home position sensor	WG8-5593	J605		E593
PI62	Punch motor clock sensor	FK2-0149	J605		E590

Ref.	Name	Parts number	Punch controller PCB	JAM	Error
PI63	Punch home position sensor	FK2-0149	J605	1644	E590

5.5.2 Microswitches

0005-8427

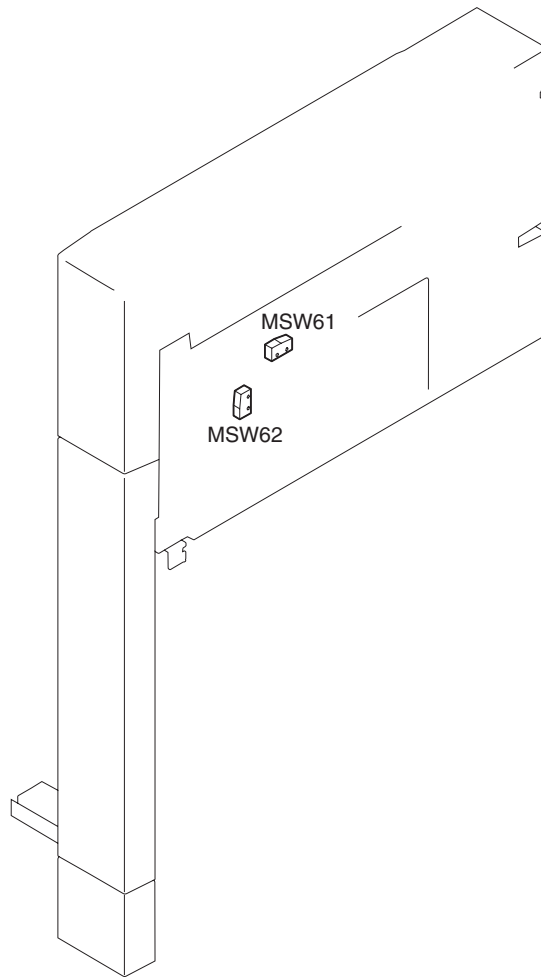

F-5-4

T-5-5

Ref.	Name	Parts number	Punch controller PCB
MSW61	Upper door switch	WC4-5128	J602

Ref.	Name	Parts number	Punch controller PCB
MSW 62	Front door switch	WC4-5128	J602

5.5.3 Motors

0005-8428

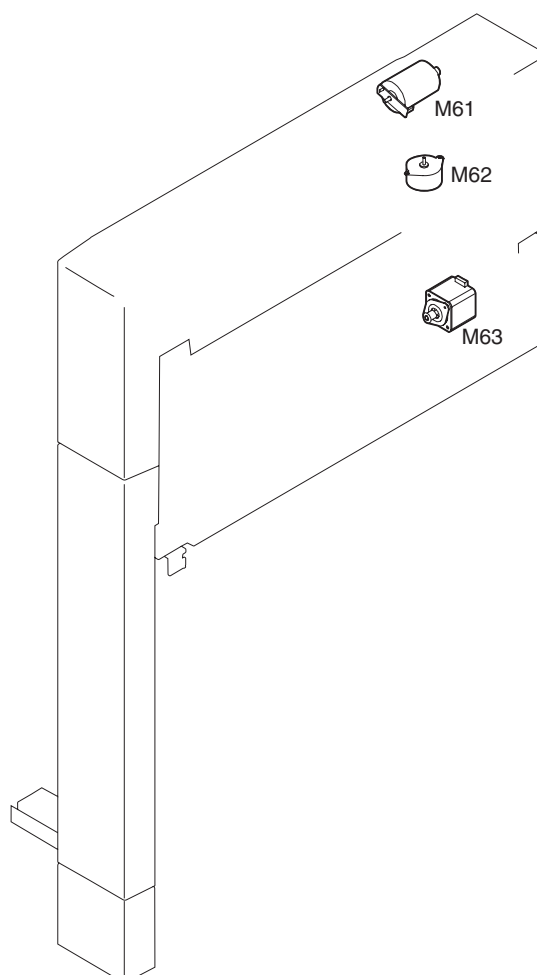

F-5-5

T-5-6

Ref.	Name	Parts number	Punch controller PCB	Error
M6 1	Punch motor	FH5-1074	J603	E590
M6 2	Horizontal registration motor	FH5-1075	J605	E593

Ref.	Name	Parts number	Punch controller PCB	Error
M63	Punch feed motor	FH5-1043	J604	

5.5.4 PCBs

0005-8429

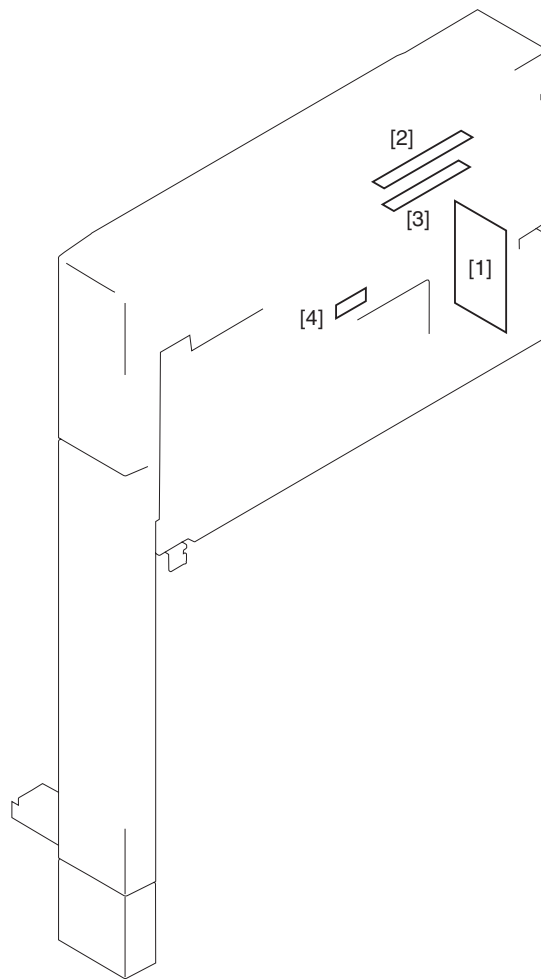

F-5-6

T-5-7

Ref.	Name	Parts number	Punch controller PCB	JAM	Error
[1]	Punch controller PCB	FG3-2885			E505

Ref.	Name	Parts number	Punch controlle r PCB	JAM	Error
[2]	Photosensor PCB	FG3-3108	J605	1002,1 102,16 45	E592
[3]	LED PCB	FG3-3107	J605		E592
[4]	Scrap full detector PCB	FM2-1521	J606		E591

5.6 Variable Resistors (VR), Light-Emitting Diodes (LED), and Check Pins by PCB

5.6.1 Overview

0003-4721

Of the LEDs and check pins used in the machine, those needed during servicing in the field are discussed.

⚠ Do not touch the check pins not found in the list herein. They are exclusively for factory use, and require special tools and a high degree of accuracy.

5.6.2 Punch Controller PCB

0003-4722

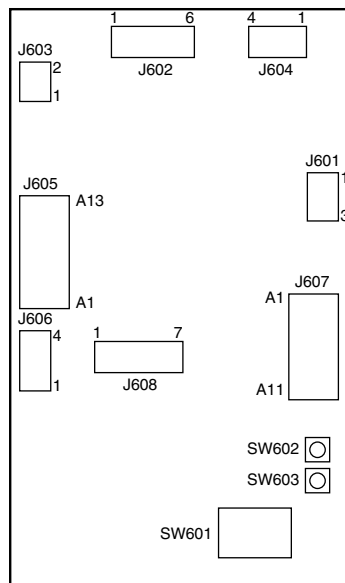

F-5-7

T-5-8

Switch	Function
SW601	Used to set various adjustment mode settings.
SW602	Used to make adjustments, start input, and store the input.
SW603	Used to store input.

5.7 Upgrading

5.7.1 Upgrading

0003-8729

Overview

A flash ROM is used for the IC601 (CPU) of the Puncher unit. To upgrade this IC, the downloader PCB (FY9-2034) is used. The operating instructions for it are given below.

How to Use the Downloader PCB (FY9-2034)

1. When to Use the Downloader PCB

The downloader PCB is used when upgrading the CPU (IC601) of the Punch Controller PCB.

2. Member part of the downloader PCB

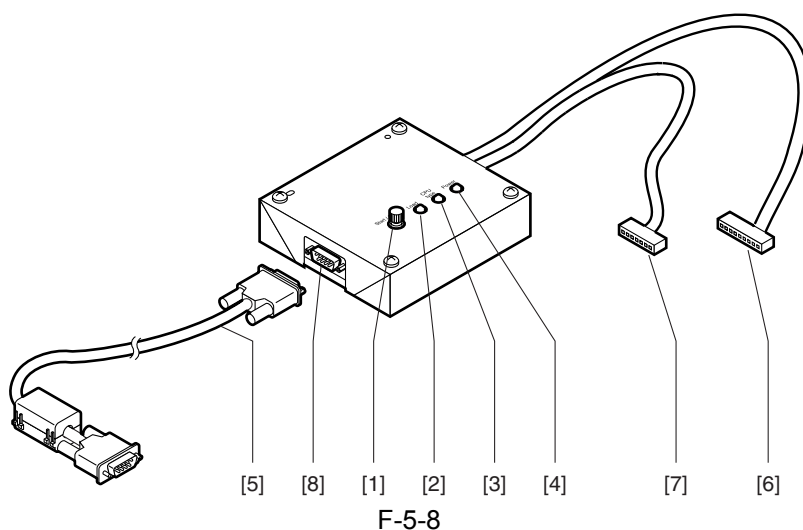

T-5-9

No.	Description	Function
[1]	START/STOP key	A key to be pressed when you start or stop download
[2]	LOAD LED	To be lit when download is available.
[3]	Model LED	To be lit when the Puncher is connected.
[4]	Power LED	To be lit when power is supplied from the Puncher to the downloader PCB
[5]	RS-232C cable (straight full wiring; 9 pins)	A cable to connect the downloader PCB and a PC. Be sure to connect the cable in a way that its ferrite core comes to the PC side.
[6]	Cable A (9 pins) Length: approx. 70cm	A cable to connect the downloader PCB and other products

No.	Description	Function
[7]	Cable B (9 pins)Length: approx. 50cm	A cable to connect the downloader PCB and the Puncher
[8]	RS-232C connector	A connector to connect an RS-232C cable to the downloader PCB

3. Necessary Tool

The following item needs to be prepared for download.

Computer (PC)

Prerequisite: The download tool (Ver. 1.73E or higher) must be downloaded to the PC.

4. Download Procedures

a. Addition of ROM data

- 1) Store ROM data to be downloaded in the 'C:\ServTool\NewROM' folder.
- 2) Start up the Service Support Tool.
C:\ProgramFiles\Service Support Tool\bpchost.exe
- 3) Select [Controlling Data].

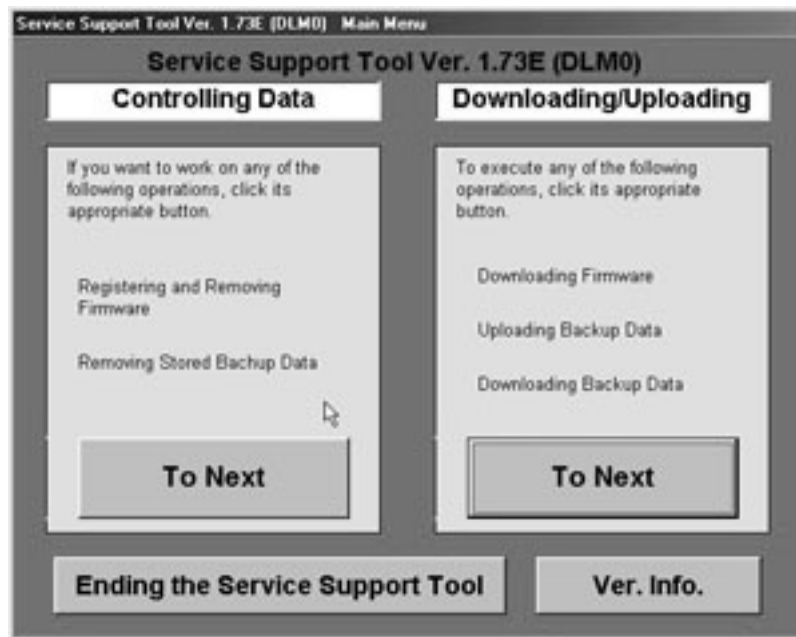

F-5-9

- 4) Select [Registering Firmware].

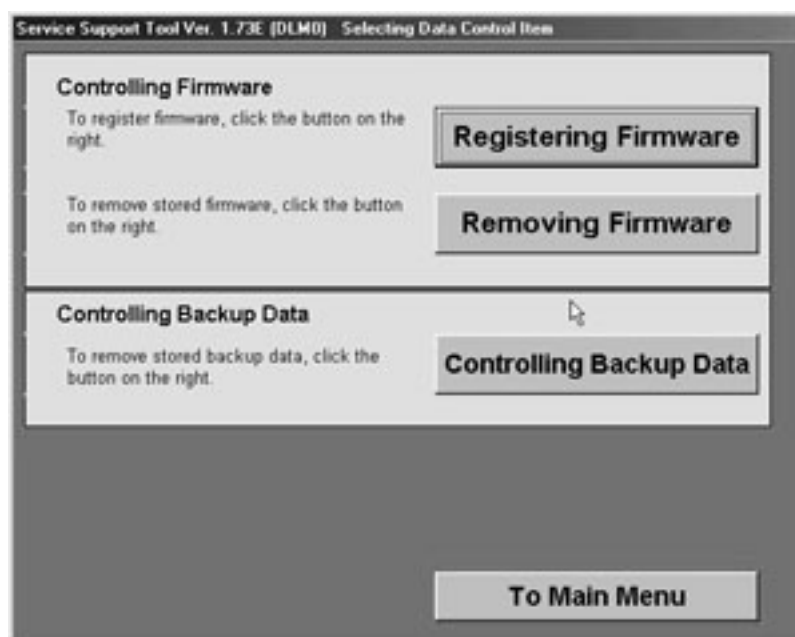

F-5-10

5) Select [Register from New ROM folder].

In response, the data will be registered, and the data inside the NewROM folder will be deleted.

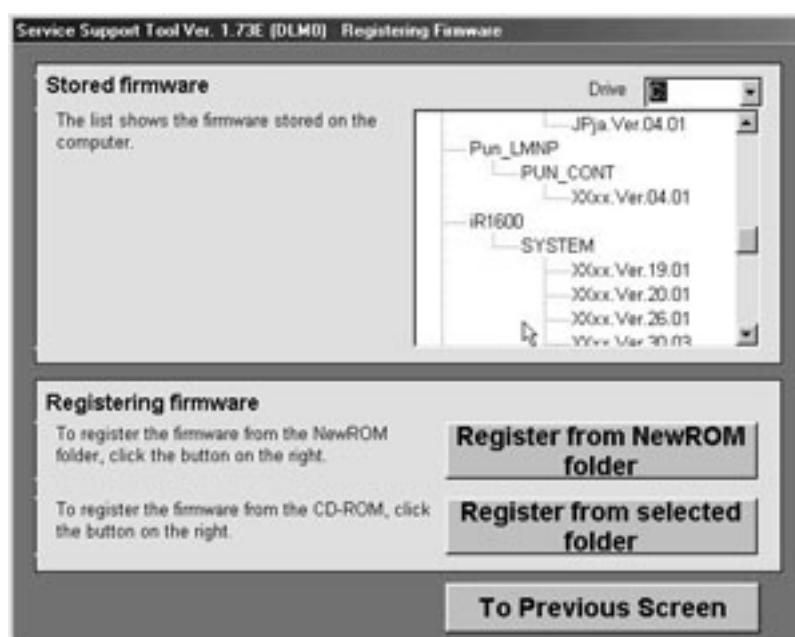

F-5-11

b. Connection to the Puncher

- 1) Turn off the power of the host machine.
- 2) Remove the rear cover of the Puncher.
- 3) Insert the cable B to J608 on the Punch controller PCB.

4) Connect the RS-232C cable to the RS-232C connectors of the circuit board and the PC.

5) Turn on the power of the host machine.

The power LED on the circuit board is lit.

c. Download

! The error code E500 might occur during download. It does not affect the download operation and its results.

1) Start up the Service Support Tool.

C:\ProgramFiles\Service Support Tool\bpchost.exe

2) Select [Downloading/Uploading].

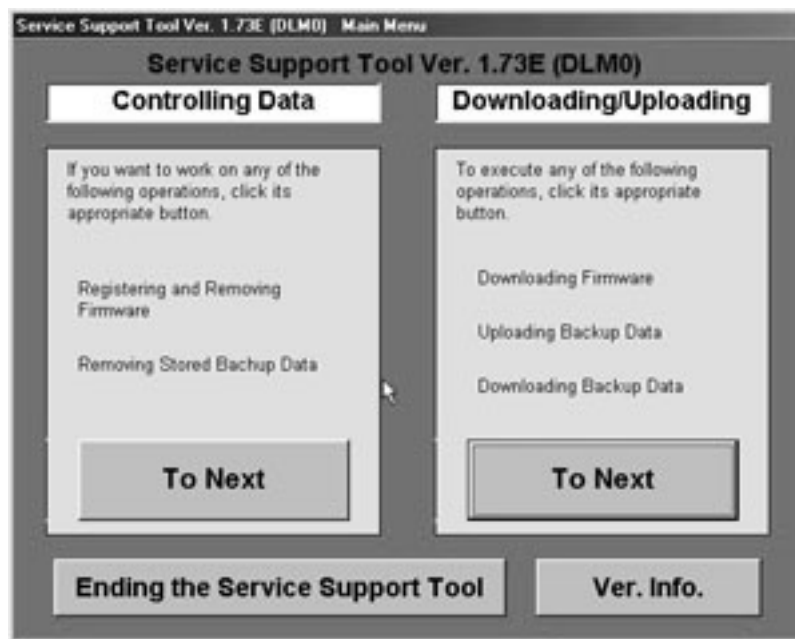

F-5-12

3) Press the START/STOP key.

LOAD LED is lit.

4) Select the Puncher.

When the model name you selected is highlighted, press the Connect key.

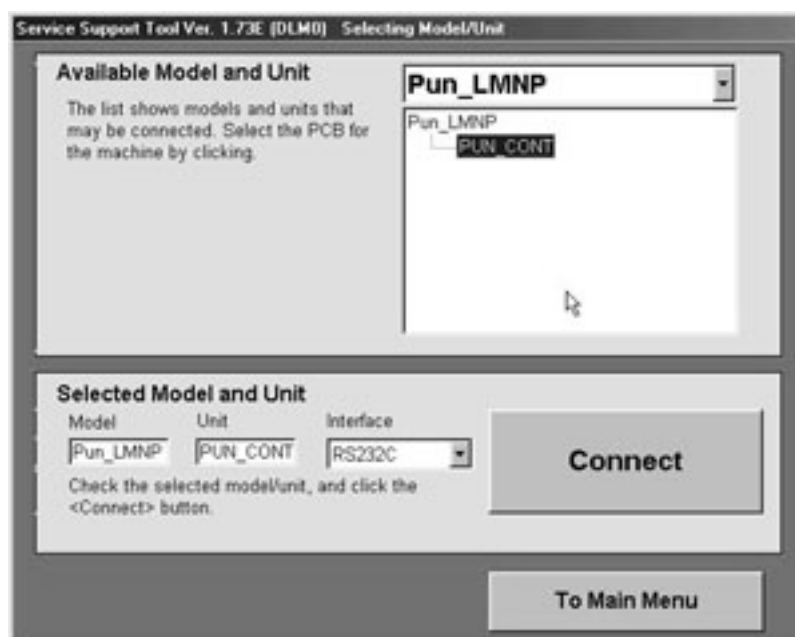

F-5-13

- 5) Follow the instructions on the screen to prepare for downloading.
A press on [OK] will bring up the next screen.

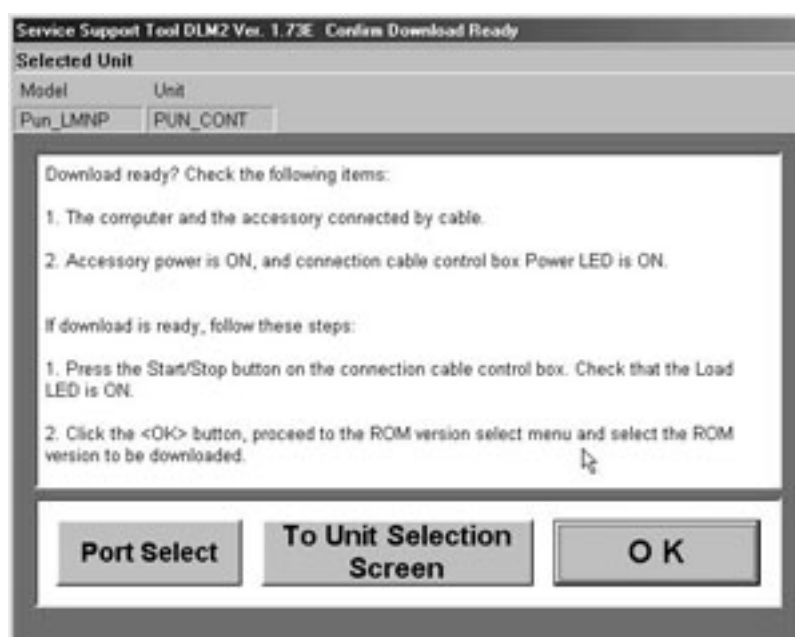

F-5-14

- 6) Select the version of the ROM to download.

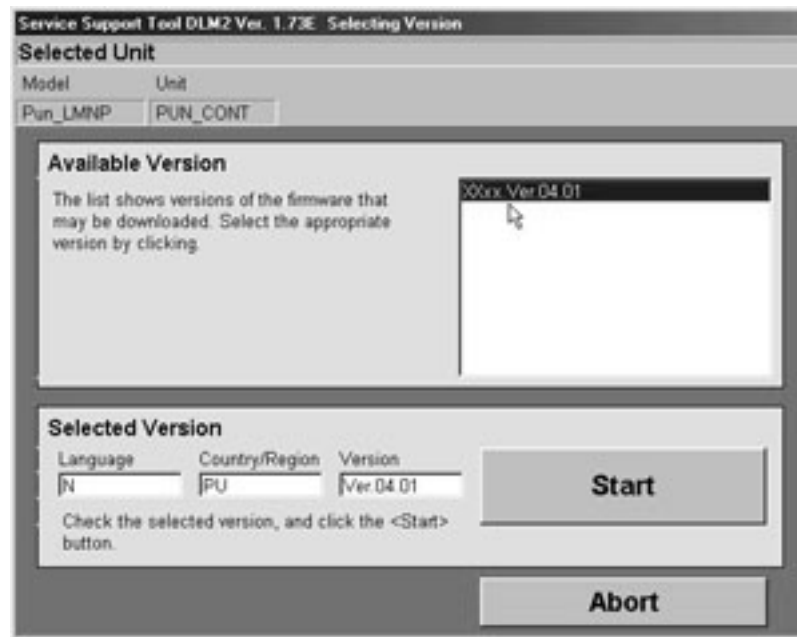

F-5-15

7) Press [Start] so that the computer and the downloaded PCB will start downloading the program.

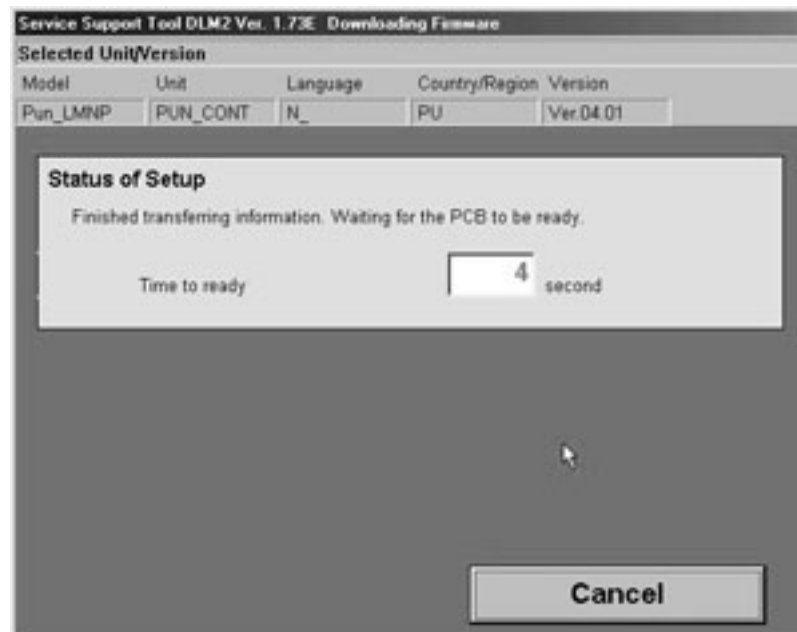

F-5-16

8) If downloading ended normally, press [OK].

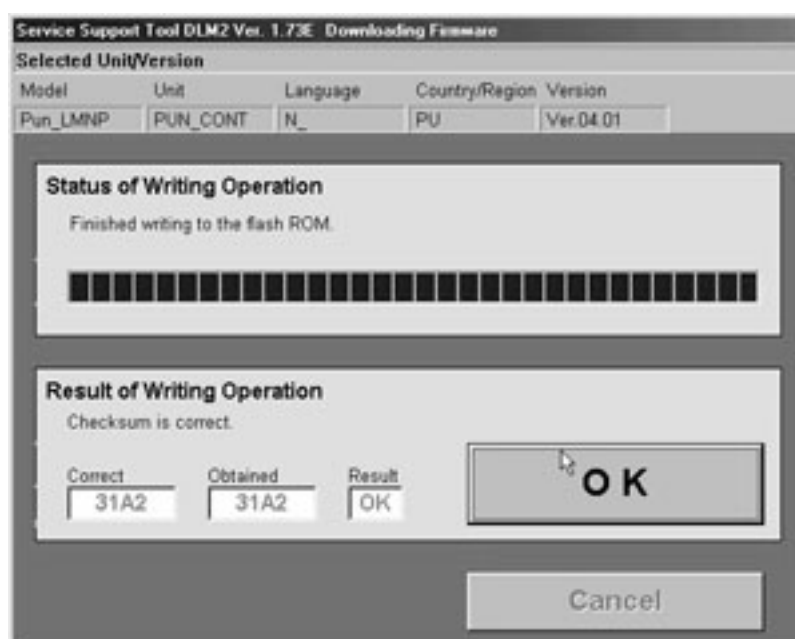

F-5-17

9) End the session as instructed on the screen.



F-5-18

5. Release of Connection

- 1) Press the START/STOP key.
LOAD LED is turned off.
- 2) Turn off the power of the host machine.
- 3) Disconnect the cable B from the Puncher.

- 4) Mount the rear cover to the Puncher.
- 5) Turn on the power of the host machine.

5.8 Service Tools

5.8.1 Solvents and Oils

0003-4723

T-5-10

No.	Name	Description	Composition	Remarks
1	Vic Clean	Cleaning: e.g., glass, plastic, rubber parts, external covers	Hydrocarbon(fluori ne family) Alcohol Surface activating agent Water	Do not bring near fire. Procure locally. Isopropyl alcohol may be substituted.
2	Lubricant	Sliding units	Silicone oil	MOLYKOTE EM30-L

Chapter 6 Error Code

Contents

6.1 Overview	6-1
6.1.1 Overview	6-1
6.2 User Error Code.....	6-2
6.2.1 Punch scrap full	6-2
6.2.2 Punch scrap overflow	6-2
6.3 Service Error Code	6-3
6.3.1 E503.....	6-3
6.3.2 E505.....	6-3
6.3.3 E590.....	6-3
6.3.4 E591.....	6-4
6.3.5 E592.....	6-5
6.3.6 E593.....	6-8

6.1 Overview

6.1.1 Overview

0003-4736

The finisher to which the unit is mounted is equipped with a mechanism (CPU on the finisher controller PCB) that runs a self check, communicating to the host machine any fault it detects in the form of a code and a detail code. In response, the host machine indicates the presence of a fault on its control panel using codes; the detail codes may be checked in the host machine's service mode.

6.2 User Error Code

6.2.1 Punch scrap full

0003-4737

T-6-1

Error Description	Occurs when	Detection timing	Machine operation	Reset
Punch scrap full	The amount of punch scraps has reached the scrap container capacity.	During punching	Normal operation will continue.	Empty the scrap container.

6.2.2 Punch scrap overflow

0003-4738

T-6-2

Error Description	Occurs when	Detection timing	Machine operation	Reset
Punch scrap overflow	The amount of punch scraps has exceeded the scrap container capacity.	During punching	Punching will be disabled.	Empty the scrap container.

6.3 Service Error Code

6.3.1 E503

0003-4739

T-6-3

Code	Detail	Error Description	Detection timing
E503	0003	Communication error	The communication with the puncher unit is interrupted.

6.3.2 E505

0003-4740

T-6-4

Code	Detail	Error Description	Detection timing
E505	0002	Backup RAM	The checksum for the punch controller PCB has an error when the power is turned on.

6.3.3 E590

0003-4741

T-6-5

Code	Detail	Error Description	Detection timing
E590	8001	Punch motor (M61)/ Punch motor clock sensor (PI62)/	The puncher does not detect the punch home position sensor when the puncher motor has been driven for 20 msec.
	8002	Punch home position sensor (PI63)	After the motor has been stopped at time of punch motor initialization, the puncher does not detect punch home position sensor.

6.3.4 E591

0003-8764

T-6-6

Code	Detail	Error Description	Detection timing
E591	8001	Scrap full detector sensor (LED6,PTR6)	The voltage of the light received is 3.0 V or less even when the light emitting duty of the scrap full detector sensor has been increased to 66% or more.
	8002		The voltage of the light received is 2.0 V or more even when the light emitting duty of the scrap full detector sensor has been decreased to 0%.

6.3.5 E592

0003-8767

T-6-7

Code	Detail	Error Description	Detection timing
E592	8001	Trailing edge sensor(LED5,PT R5)/	The voltage of the light received is 2.5 V or less even when the light emitting duty of the trailing edge sensor has been increased to 66% or more.
	8002	Horizontal registration sensor (LED1 to 4,PTR1 to 4)	The voltage of the light received is 2.0 V or more even when the light emitting duty of the trailing edge sensor has been decreased to 0%.
	8003		The voltage of the light received is 2.5 V or less even when the light emitting duty of the horizontal registration sensor 1 (LED1,PTR1) has been increased to 66% or more.
	8004		The voltage of the light received is 2.0 V or more even when the light emitting duty of the horizontal registration sensor 1 (LED1,PTR1) has been decreased to 0%.
	8005		The voltage of the light received is 2.5 V or less even when the light emitting duty of the horizontal registration sensor 2 (LED2,PTR2) has been increased to 66% or more.
	8006		The voltage of the light received is 2.0 V or more even when the light emitting duty of the horizontal registration sensor 2 (LED2,PTR2) has been decreased to 0%.
	8007		The voltage of the light received is 2.5 V or less even when the light emitting duty of the horizontal registration sensor 3 (LED3,PTR3) has been increased to 66% or more.
	8008		The voltage of the light received is 2.0 V or more even when the light emitting duty of the horizontal registration sensor 3 (LED3,PTR3) has been decreased to 0%.
	8009		The voltage of the light received is 2.5 V or less even when the light emitting duty of the horizontal registration sensor 4 (LED4,PTR4) has been increased to 66% or more.
	800A		The voltage of the light received is 2.0 V or more even when the light emitting duty of the horizontal registration sensor 4 (LED4,PTR4) has been decreased to 0%.

6.3.6 E593

0003-4742

T-6-8

Code	Detail	Error Description	Detection timing
E593	8001	Horizontal registration motor(M62)/ Horizontal registration home position sensor (PI61)	At time of horizontal registration motor initialization, the punch slide unit does not leave the horizontal home position sensor even when it has been driven for 9 mm.
	8002		At time of horizontal registration motor initialization, the punch slide unit does not return to the horizontal registration home position sensor even when the unit has been driven for 37 mm.

Apr 9 2004

Canon